

Operation Manual:

SU320CSX

Mil-Rugged, High Sensitivity, Small SWaP InGaAs SWIR Camera



SENSORS
UNLIMITED

UTC Aerospace Systems

Distribution in the UK & Ireland



**Characterisation,
Measurement &
Analysis**

Lambda Photometrics Limited

Lambda House Batford Mill
Harpenden Herts AL5 5BZ
United Kingdom

E: info@lambdaphoto.co.uk
W: www.lambdaphoto.co.uk
T: +44 (0)1582 764334
F: +44 (0)1582 712084

The modifiers and phrases SUI ® , Sensors knows IR ® , Imaging Beyond Visible ™ , Visible-InGaAs ™ , NIR Perfect ™ , NI ® , IMAQ ™ , LabVIEW ® and Camera Link ® are used in this manual. “SUI”, “Sensors knows IR”, and “NIR Perfect” are all trademarks of Sensors Unlimited, Inc., a wholly-owned subsidiary of United Technologies Corporation. “NI, IMAQ and LabVIEW are trademarks of National Instruments. Camera Link™ is a registered trademark of the Automated Imaging Association. Windows® and the associated XP®, Vista®, Win7®, Win8®, etc. are registered trademarks of Microsoft Corporation in the United States and other countries. All other trademarks or intellectual property mentioned herein belong to their respective owners.

Every effort is made to ensure the information in this manual is accurate and reliable. Use of the products described herein is understood to be at the user’s risk. Sensors Unlimited assumes no liability whatsoever for the use of the products detailed in this document and reserves the right to make changes in specifications at any time and without notice.

Table of Contents

Table of Contents	3
1. Introduction	5
1.1. Foreword	5
1.2. System Description	5
1.3. System Contents	6
1.4. Safety Considerations	7
1.5. Thermal Management	7
1.6. Camera Cleaning	8
2. Getting Started Guide	9
2.1. Mechanical Mounts, Optics, and Electrical Connections	9
2.2. Frame Grabber Options and Installation	15
2.3. SUI Image Analysis Freeware	18
2.4. Powering the Camera for the First Time	18
3. Camera Link Data Interface	20
4. Principles of Operation	23
4.1. Focal Plane Array Operation	23
4.2. Camera System Operation	24
5. Camera Functions and Control Software Interface	26
5.1. Communication Protocol	26
5.2. Command Format and Response	26
5.3. Startup Messaging	28
5.4. Command Set	28
5.5. Configuration Commands	28
5.6. Serial Communication Interface Commands	34
5.7. Non-Uniformity Corrections (NUCs) Commands	38
5.8. Bad Pixel Corrections	41
5.9. Automatic Gain Control (AGC) Commands	47
5.10. Image Enhancement Commands	51
5.11. Pixel Clock Commands	54
5.12. Frame and Exposure Control Commands	55

5.13.	<i>Trigger Commands</i>	57
5.14.	<i>Gain Commands</i>	64
5.15.	<i>Thermal Commands</i>	65
5.16.	<i>Digital Output Commands</i>	68
5.17.	<i>Camera Information Commands</i>	69
5.18.	<i>Binning Mode Commands</i>	78
5.19.	<i>Test Commands</i>	79
5.20.	<i>Macro Commands</i>	81
5.21.	<i>Windowing Commands</i>	82
6.	Specifications	87
6.1.	<i>Mechanical Specifications</i>	87
6.2.	<i>Environmental and Power Specifications</i>	87
6.3.	<i>Electro-Optic Performance Specifications</i>	88
7.	Product Support	89
	<i>Common Problems and Solutions</i>	89
8.	Customer Support	90
9.	Warranty	91
10.	LIST OF ABBREVIATIONS	92
11.	NOTES	93
	APPENDIX A: Camera Command Summary	94

1. Introduction

1.1. Foreword

This manual applies to all variants of the SU320CSX camera. These are collectively referred to as the CSX camera. Appendix B to this manual contains configuration information that is specific to your camera variant. It is included as a separate document on the mini-disc or media card that ships with the camera. **The user should become very familiar with the information provided in Appendix B. If you cannot locate Appendix B, please contact SUI for assistance.**

Important precautions are located in Section 1.4 Safety Considerations and 1.5 Thermal Management. Refer to these sections prior to powering the camera.

Important notes and specific setup steps are indented and in bold.

1.2. System Description

The CSX camera family offers users a mil-rugged, small size, weight, and power (SWaP) Indium Gallium Arsenide Infrared Camera. This manual documents these model families:

- SU320CSX-12.5B Small SWaP 320 x 256 SWIR
- SU320CSX-12.5B Small SWaP 320 x 256 NIR/SWIR

This manual pertains to both the enclosed and the OEM (open-frame) versions of the CSX. The software commands and optical / electrical interfaces are identical between the enclosed and OEM versions, while the physical dimensions are unique. Some shipping and accounting documents may also refer to the camera similar to SU320CB-12.5B-ENC-FH-STD-[sequence].

Designed for laboratory, factory, or military field use, the CSX camera features a high sensitivity imager which includes a single-stage TEC for thermal stabilization at high operating temperature setpoints, allowing a very stable Non Uniformity Correction (NUC) set to produce high quality imagery. The optical sensitivity ranges from 0.9 μm . to 1.7 μm for the standard InGaAs camera, and from <0.7 μm to 1.7 μm for the NIR/SWIR InGaAs camera.

The focal plane array (FPA) produces a video signal digitized with a resolution of 12 bits or greater using an onboard analog-to-digital converter. The user can select to process the digitized data using non-uniformity corrections (NUCs). The NUCs compensate for exposure time, dark current, and gain tolerances.

The digital signal is available in a base Camera Link compatible format or, if specified upon order, an Analog EIA170 (RS170, essentially black-and-white NTSC) output, which allows display on standard monitors.

Camera Link is a serial communication protocol standard designed for computer vision applications. It was designed for the purpose of standardizing scientific and industrial video products including cameras, cables, and frame grabbers.

Factory corrections are available for a range of preconfigured integration time and FPA sensitivity combinations, which are referred to as OPRs. The OPRs are detailed in Appendix B, which can be found as a separate document on the disc that shipped with the camera. Camera operation may be customized using ASCII commands sent through the Camera Link asynchronous serial communication port.

The camera features no moving parts and may be powered indefinitely, as long as it is thermally managed correctly (see Section 1.5 Thermal Management). There is no power switch on the camera. When an AC adapter is used, the best practice is to supply and remove power at the source rather than at the load. Therefore, when using the supplied AC adapter, make the connection at the wall last when powering the camera and first when removing power from the camera. Do not make or break the connection at the camera or on the cable while power is being supplied. See Section 2.1.3 for more information about the power interface.

1.3. System Contents

A complete order for an enclosed SU320CSX may include the following:

- SU320CSX camera body
- AC adapter (power supply)
- Storage case
- Assorted cables and adapters.
- Sensors Unlimited mini-disc or USB media card containing documentation
 - This user manual
 - Appendix B
 - software/freeware SUI-Image Analysis
 - configuration file for compatible National Instruments frame grabber cards (*.ICD file)
- Lens

A complete order for an OEM SU320CSX may include the following:

- SU320CSX-OEM camera chassis
- OEM Accessory Kit, including:
 - AC adapter (power supply)
 - Lens
 - Storage case
 - Assorted cables and adapters.
 - Sensors Unlimited mini-disc containing documentation
 - This user manual
 - Appendix B
 - software/freeware SUI-Image Analysis
 - configuration file for compatible National Instruments frame grabber cards

This break-out allows volume arrangements to eliminate unused parts.

Options include:

- Alternate outputs and output connectors available upon request at time of order (e.g. ST4 board-to-board connector, analog, USB3, Ethernet outputs, etc.)
- Alternate lens mounts and lenses
- Alternate Camera Link Frame grabber cards and cables

1.4. Safety Considerations

The camera can be powered using a DC power supply capable of providing a minimum of 4 Watts of continuous power. The camera is supplied with an appropriate universal mains power supply. Do not exceed the voltage maximum or damage might occur.

If you supply your own power, it is critical that the power connections be made to the proper connector pins. See Section 2.1.3 Power, Trigger, and Sync for details.

The focal plane array is mounted behind a broadband antireflective-coated protective window. When changing lenses or mounting the camera in any optical arrangement, take care not to scratch or touch this window.

To prevent fire, shock hazard or damage to the camera, do not expose to rain or excessive moisture. Do not disassemble camera. Do not remove screws or covers. There are no user serviceable parts inside. Removal of any panel will void the warranty.

When handling the camera, take precautions to avoid electro-static discharge (ESD) to any exposed electrical connector pins.

1.5. Thermal Management

Caution: Do not power the CSX camera until you have considered thermal management. The camera itself does not dissipate heat quickly enough to prevent over-heating under all conditions. Monitoring of the camera case temperature, system temperature, and thermoelectric cooler (TEC) lock are highly recommended to prevent overheating. The case temperature can be monitored by a user-supplied thermocouple or other sensor. System temperature closely tracks case temperature, and can be queried with the SYSTEM:TEMP? command as described in Section 5.15.1 Get System Temperature. The camera can be placed in a higher TEC setpoint to reduce power consumption with the MACRO command as described in Section 5.20.1 Play Macro Command. If the camera temperature is too high, forced convection from an external fan or conduction to an external heat sink is highly recommended. Due to the small size of the camera, the camera may overheat within minutes of applying power if no external cooling or heat sinking is provided.

The CSX camera has been designed to efficiently transfer heat from the focal plane array and other heat-generating components to the chassis. The camera will function properly while the chassis temperature is maintained within the specifications listed in Table 1.

Table 1. The case temperature can be measured anywhere on the camera chassis, the system temperature and TEC lock status can be queried as described in sections 5.15.1 Get System Temperature and 5.15.3 Get TEC Lock Status. The MACRO command changes camera TEC setpoint as described in Section 5.20.1 Play Macro Command. TEC is locked when the thermoelectric cooler is able to maintain the FPA at its setpoint. The camera will lose TEC lock when the low or high case temperature for a given TEC setpoint is exceeded. See

Table 1 for the case temperatures that correspond to each TEC setpoint.

Table 1. Recommended Case Temperature Range per TEC Setpoint

TEC Setpoint (°C)	MACRO	Low Case Temperature (°C)	High Case Temperature (°C)
18	0	-5	35
32	1	0	45
45	2	20	60

1.6. Camera Cleaning

Power down the camera prior to performing any camera cleaning operation.

Use a soft cloth moistened with a small amount of isopropyl alcohol to clean the outside of the camera enclosure or the power supply housing.

If the protective window of the focal plane array requires cleaning, the following steps are recommended:

1. With the focal plane array mounted in the camera, use clean, dry compressed air to blow loose particles off the window. This step alone is often sufficient to clean the window. **Do not use compressed air gas canisters. They may spray cold fluid that can thermally shock the window.**
2. Moisten a lint-free lens cleaning paper with isopropyl alcohol and carefully wipe the surface of the window by dragging the moistened paper from one edge of the window to the other in a single motion. The paper may need to be folded so that it does not contact any surface other than the glass. Use the paper only once and wipe in one direction across the window surface. If the surface is still not clean, repeat this step as necessary, always wiping in the same direction using a new piece of moistened cleaning paper until the window is clean. It is important to use isopropyl alcohol because it acts as a lubricant when wiping the surface of the window.

2. Getting Started Guide

This guide is divided into four sections. The first covers mechanical mounting of the camera, optic, and connecting to the camera inputs and outputs. The second section covers frame grabber options and installation. The third section covers SUI Image Analysis software, and the fourth guides the user in powering on the camera for the first time. Users are strongly advised to review these four sections prior to powering on the camera.

Specific steps are bolded and indented.

2.1. Mechanical Mounts, Optics, and Electrical Connections

The CSX camera comes equipped with mounting provisions on all four sides (left, right, top, bottom). Two threaded holes are present on each side, separated by 19.1mm and set back 3.0mm from the front flange. Refer to Section 2.1.1 Mechanical Mounts for detailed dimensions.

The lens mount is a 1-inch hole with 32 threads/inch, which adheres to the C-mount standard 1-32 UN 2A. However, the camera back focal distance (flange to FPA) is not C-mount compliant and requires the included C-mount spacer to match the C-mount standard. This hybrid mounting plate design permits adapting the camera to a variety of standard lens mount formats, especially those with short back focal distances. See Section 2.1.2 Optical Mounts and Other Optical Considerations for additional details.

There are two electrical connections on the back of the camera, as well as a status indicating LED, which is described in Section 5.15 Thermal Commands. The larger connector is a 26-pin Shrunken Delta Ribbon (SDR) standard connector which carries the Camera Link compatible video signal and LVDS serial communication (serial over Camera Link), as detailed in Section 2.1.4. The smaller 14 pin SDR standard connector carries power, trigger, and sync, which are fully detailed in Section 2.1.3.

2.1.1. Mechanical Mounts

If mounting the camera, refer to the following dimensions:

Dimensions (W x H x D) excluding connectors and lens	Enclosed/OEM	1.25"W x 1.25"H x 1.10"D 31.8W x 31.8H x 28D mm
Weight	Enclosed	≤50 g
	OEM	≤45 g

Mount the camera with the 4-40 tapped mounting holes located on the top, bottom, left, or right side of the camera.

Additional dimensions are provided in the mechanical drawings below (Figure 1 and Figure 2).

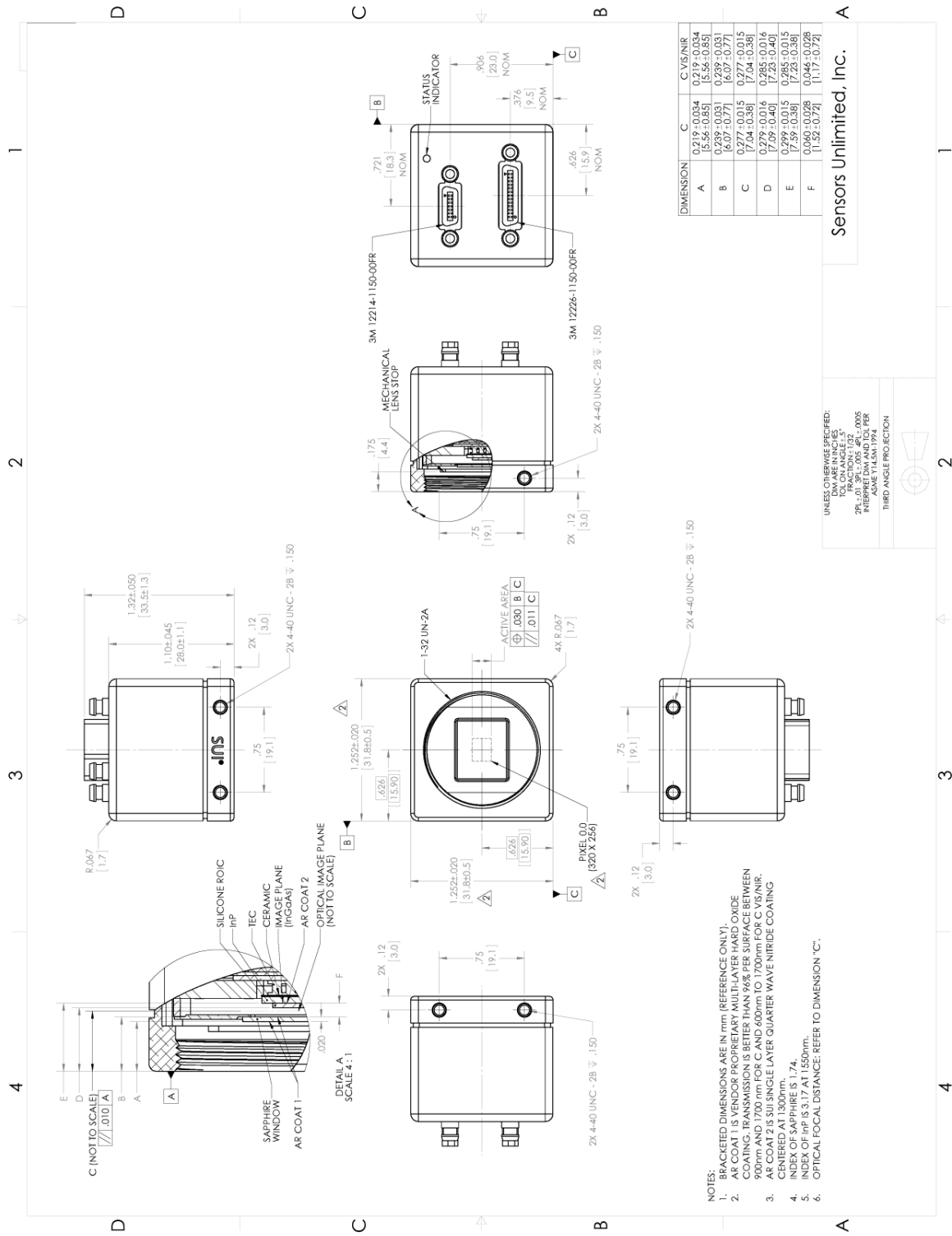

Figure 1. Mechanical drawing of enclosed CSX.

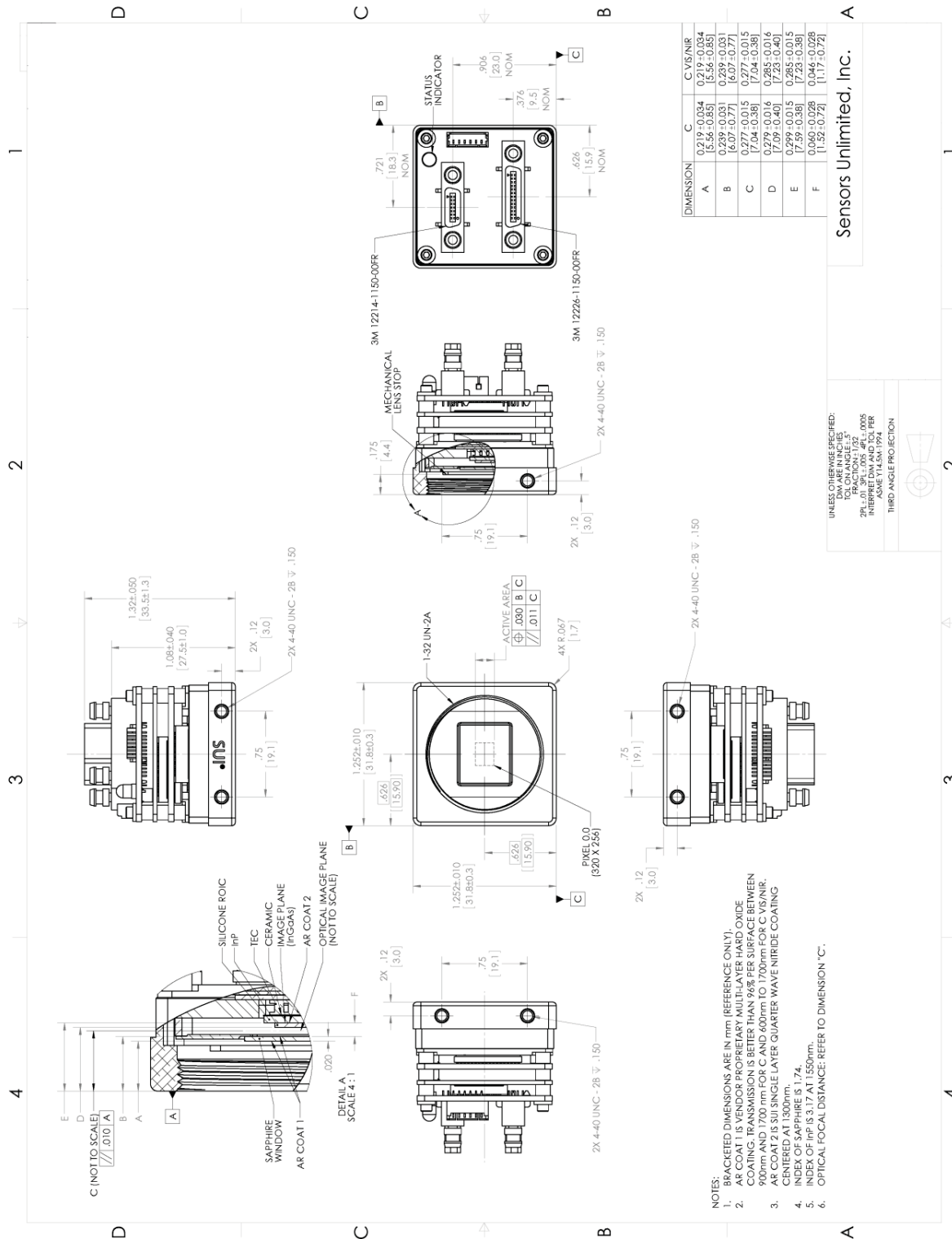

Figure 2. Mechanical drawing of OEM CSX.

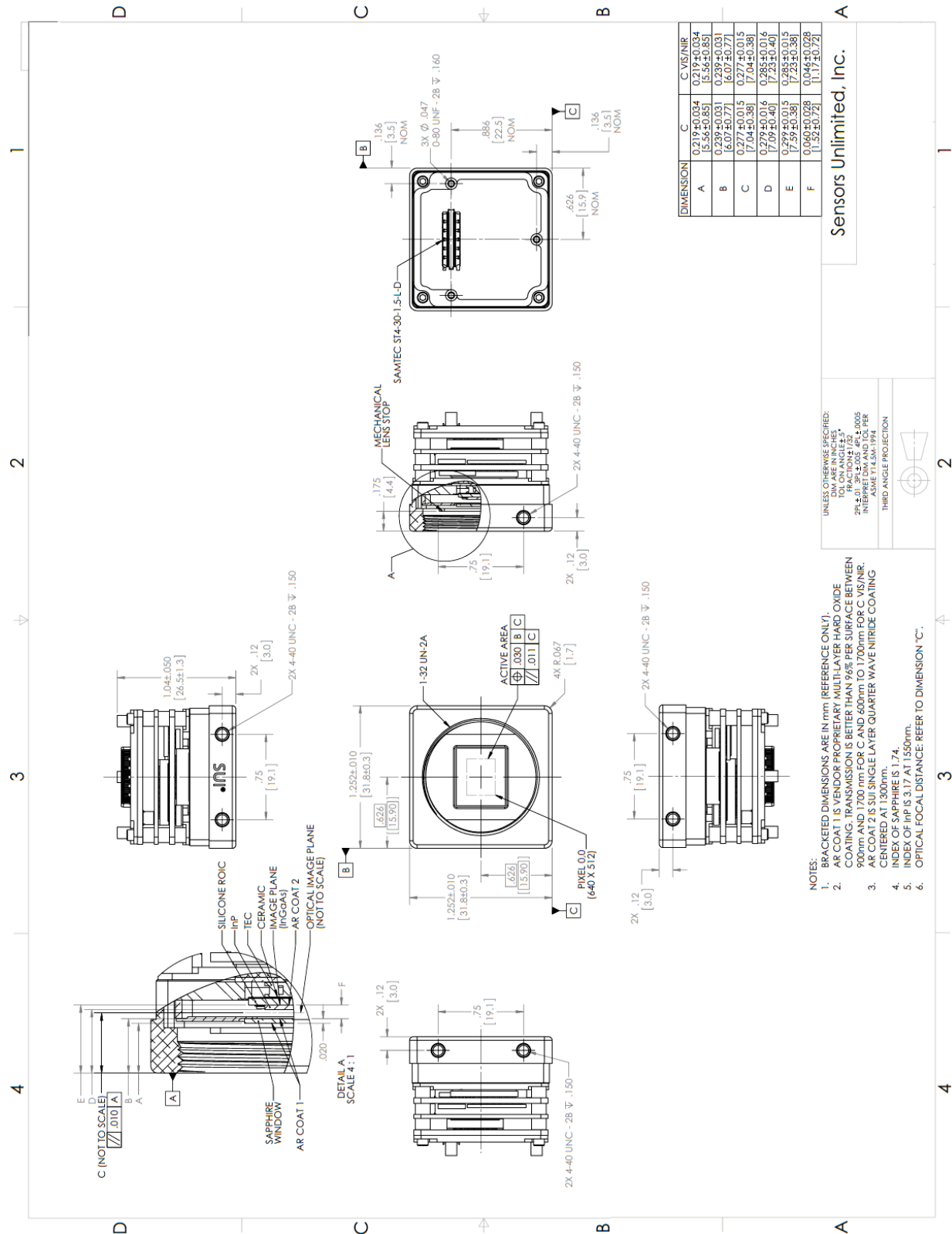

Figure 3. Mechanical drawing of OEM CSX with optional ST4 board-to-board connector.

2.1.2. Optical Mount and Other Optical Considerations

The lens mount is a 1-inch hole with 32 threads/inch, which adheres to the C-mount standard 1-32 UN 2A. However, the camera back focal distance (flange to FPA) is not C-mount compliant and requires the included C-mount spacer to match the C-mount standard. This hybrid mounting plate design permits adapting the camera to a variety of standard lens mount formats, especially those with short back focal distances.

Screw the lens into the lens mount. If using a SUI supplied SOLO lens, no spacer is needed. Other lenses require the C-mount spacer between the lens and the camera lens mount.

The C-mount standard back focal distance is 0.69 inch / 17.5mm. The camera back focal distance is shown in Figure 1 and Figure 2 as dimension E and is dependent on the spectral response of the camera. The back focal distance dimension for SWIR-only cameras is listed in the middle column labeled “C” and the back focal distance dimension for NIR/VIS cameras is listed in the column labeled “C VIS/NIR”.

The optical image plane (dimension C on Figure 1 and Figure 2) takes the index of refraction at 1550nm and thickness of the sapphire window and InP layer into account.

The spectral response of the CSX camera is broad and beyond the range for which visible consumer and commercial lenses have been designed. The use of SWIR-optimized lenses is strongly recommended. Contact Sensors Unlimited, Inc. for lens options and recommendations. Commercially available visible (non-SWIR optimized) optics are suitable for some SWIR imaging applications, particularly in bright lighting conditions.

In cases where a visible lens is used, it should be noted that the lens focus markings will be mis-calibrated due to the wavelength dependence of the refraction properties of the glass. Additionally, the CSX camera does not include controls for auto iris or auto focus. Auto iris lenses that permit manual control of the aperture in “stop-down aperture” or “depth of field” preview mode may be adapted to work with the CSX camera.

Some lenses default their default iris position to full open. If the lens does not default to full aperture, locate and disable the mechanical metering lever that controls the aperture via a stop or other mechanical means to hold the lever in a desired f/stop position.

If necessary, contact Sensors Unlimited, Inc. for lens options and recommendations.

2.1.3. Power, Trigger, and Sync Interface

The CSX requires an adapter cable to mate the power, trigger, and sync connectors to the chassis. Attach the supplied Power, Sync, Trigger cable (PN 8030-0020) to the camera chassis POWER/AUX connection by following these steps:

WITH ALL COMPONENTS DEENERGIZED: Connect the provided 14 pin SDR Power, Sync, Trigger cable (PN 8030-0020) to the camera, inserting the connector until it is fully seated and the shell is parallel to the mating panel surface. Snug (do not overtighten) the cable retention screws. Do not make or break this connection while power is being supplied.

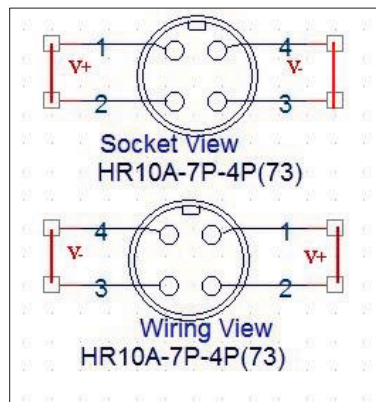

Figure 4. Hirose Power Connector Diagram

An AC adapter is provided with a cable that connects to the back panel of the camera via a supplied hybrid adapter cable. The adapter cable mates with the connector labeled POWER/AUX, and provides a snap-fit connector of the Hirose HR10A-7P-4P(73) series on the fly end, as well as supplies SMA connectors for the Sync and Trigger logic connections. The mating Hirose connector is on the auto-selecting AC adapter which plugs into 100-240 VAC (47 Hz - 63 Hz) mains; international mains adapter blades are available.

The Hirose connector provides + and - power across the 4 contacts. Pins 1 - 2 are DC + and pins 3-4 are DC -. DC- is isolated from ground by a protection resistor, capacitor, and ferrite slug, yet it is not forbidden to ground the negative supply (review this connection if unusual noise coupling is noticed). If you are wiring to this connector, a handy hint is that commercial connectors will emboss or otherwise label the pin numbers onto the connector to insure there is no confusion as to which side of the indexed connector you are viewing. **NOTE: Insure wiring polarity is correct. Reversed connection is a common cause of damage.**

If the supplied AC adapter is being used, insert the power connector on the provided AC adapter (PN 8000-0726) into the camera power adapter cable until snap-locked. Do not make or break this connection while power is being supplied.

If the supplied AC adapter is not being used, test the power source for proper voltage, polarity, and pin connections before connecting the power cable to the camera. Do not exceed the voltage maximum or damage may occur. The power source used must conform to the power specifications with regard to maximum power and ripple, etc. to ensure proper camera performance.

Regardless of the source of power (supplied AC adapter, lab power supply, etc.) the best practice is to supply and remove power at the source rather than at the load. Therefore, when using the supplied AC adapter, make the connection at the wall last when powering the camera and first when removing power from the camera. Do not make or break the connection at the camera or on the cable while power is being supplied.

If using the trigger input or sync output, connect the appropriate adapter cable to the external device. The Trigger and Sync is compliant to 3.3V CMOS logic in terms of supply voltage, crossover points, and loading. Safety is built in should a compatible trigger be applied while the camera is not powered. The trigger, synch, and video shells are tied to Digital ground through individual inductors. V- is tied to

ground through a ferrite inductor as well. The signal source must be compliant with the specifications described in Section 5.13 Trigger Commands.

2.1.4. Electrical Interfaces

Two electrical connector interfaces to the CSX camera are located on the camera back panel, as well as a status indicating LED. The LED behavior is described in Section 5.15 Thermal Commands and in 5.13 Trigger Commands. The larger connector is a 26-pin Shrink Delta Ribbon (SDR) standard connector which carries the Camera Link compatible video signal and LVDS serial communication (serial over Camera Link). The smaller 14 pin SDR standard connector carries power, trigger, and sync.

The digital data interface is through a base Camera Link compatible interfaces using low-voltage differential signaling (LVDS). The CSX can be interfaced to most frame grabbers, and have verified operation with National Instruments and Imperx frame grabbers. Power over Camera Link (PoCL) is not supported and therefore special PoCL cables are compatible but not required.

To connect to the digital interface, connect the separately-supplied SDR Camera Link cable to the camera, inserting the connector until it is fully seated and the shell is parallel to the mating panel surface. Snug (do not overtighten) the cable retention screws.

2.1.5. Analog Video Output (must be specified upon order)

Video is EIA170 (compatible to RS-170, NTSC). If interfacing to an analog monitor, connect the supplied analog cable to the snap-connection Video Out on the camera. Connect the BNC end to an analog monitor. If using a television for video display, use the supplied BNC-RCA adapter and connect to the yellow Video input jack (ignore the red and white audio connections); set TV to 'Video' input per TV operating instructions.

2.2. Frame Grabber Options and Installation

The digital output allows the user to connect the camera to a computer frame grabber through a Camera Link® cable. This connection provides bi-directional communication. Image data flows from the camera to the computer, and camera control information flows in both directions. A Camera Link® frame grabber card is used to connect the camera link cable to the computer. Sensors Unlimited, Inc. fully supports National Instruments frame grabber cards and provides limited support for Imperx laptop frame grabber cards.

The CSX is designed to communicate with third part fully-compatible Camera Link frame grabber cards, which may require the user to build a configuration file with the assistance of the frame grabber source documentation and software. The CSX camera should work with frame grabbers from Matrox, Pleora Technologies, and other manufacturers. Pleora provides Camera Link to GigE and Camera Link to USB3 converters which have been demonstrated to work with the CSX camera. However, SUI provides only limited support for these and other frame grabbers.

There are converters available to convert the Camera Link® signal to USB3 or GigE should you require this capability, and SUI may provide these outputs natively on the camera in the future. Contact SUI for more information.

2.2.1. National Instruments Frame Grabbers



Figure 5. National Instruments frame grabber cards for desktop computers

National Instruments (NI) produces a range of Camera Link® frame grabbers for desktop computers. Their product line can be found at their website. Please contact Sensors Unlimited, Inc. for specific recommendations.

A Camera Link® cable is used to connect the Digital port on the back of the camera to the frame grabber. There are two common versions of the cable connection: Mini Delta Ribbon (MDR) and the smaller Shrunk Delta Ribbon (SDR). The CSX camera is fitted with a SDR connector while the NI frame grabber cards are fitted with MDR connectors. Customers using a NI frame grabber should be sure that they are using an MDR-SDR (or SDR-MDR) cable for compatibility with their camera and frame grabber.

2.2.2. Imperx Frame Grabbers

As late 2015, National Instruments does not provide a Camera Link® solution for laptops. However, frame grabbers for laptops can be purchased from other manufacturers. Imperx, for example, produces a FrameLink Express card for laptops equipped with an ExpressCard slot. More information can be found at the Imperx website. SUI provides limited support for Imperx frame grabber cards.



Figure 6. Imperx FrameLink Express frame grabber for laptops.

SUI recommends that new customers check with their frame grabber supplier for compatibility with their desktop or laptop computer. Each frame grabber is designed to interface with specific hardware ports in

the computer. Failure to check with the frame grabber supplier may result in compatibility issues when installing the frame grabber in the computer.

2.2.3. Frame Grabber Installation

Video acquisition and camera control software is dependent on the frame grabber used. New users are advised to connect to the camera with software provided by the frame grabber manufacturer prior to connecting with SUI Image Analysis. For example, if using a National Instruments frame grabber, it is best to test the connection with NI Measurement and Automation eXplorer (NI MAX) software first. Or, if using an Imperx frame grabber, it is best to test the connection with Imperx FrameLink Express software.

Once data is successfully grabbed from the camera with NI MAX or Imperx FrameLink Express, users may want to switch to SUI Image Analysis (SUI IA) software for image/video acquisition, camera control, and basic image analysis. SUI IA is compatible with both National Instruments brand Camera Link frame grabber boards and Imperx frame grabber cards. It is not compatible with other frame grabbers. SUI IA may be operated in offline mode, with no connection to the camera for post-processing. See Section 2.3 for more information on SUI Image Analysis software.

2.2.4. National Instruments Frame Grabber Setup

If a National Instruments frame grabber is being used, National Instruments IMAQ must be installed. NI-IMAQ Vision is National Instruments library of powerful functions for image processing that is distributed with their imaging frame grabber cards. This software library easily integrates with National Instruments LabVIEW Software, an extensive instrument-programming environment. License to the software is given with ownership of the frame grabber board. **NI-IMAQ Version 4.7.3, which is included in NI Vision Acquisition Software published August 2013, is the most recent version compatible with SUI Image Analysis 6.x and earlier versions. If necessary, either roll back NI-IMAQ to the August 2013 version, or contact us for updated versions of SUI Image Analysis.**

Install NI-IMAQ and other National Instruments software and hardware according to National Instruments' instructions.

The camera configuration file (an .ICD file) is provided on the Sensors Unlimited minidisc shipped with the camera. This configuration file properly configures the frame grabber for the CSX's Camera Link interface timing and allows the selection of camera Operational Modes. Use NI Measurement and Automation Explorer (NI MAX) to load the .icd file to the default directory.

2.2.5. Imperx FrameLink Express Frame Grabber Setup

A laptop computer equipped with an ExpressCard interface is required to support Imperx FrameLink Express Frame Grabbers. Install the FrameLink Express Application according to the manufacturer's instructions. SUI recommends FrameLink Express Application Version 1.4.0, which can be obtained from Imperx on request. Once the software is installed, follow these steps to ensure proper recognition of the frame grabber card:

1. Shut down the laptop computer.
2. Insert the FrameLink Express Frame Grabber into the ExpressCard interface.

3. With the camera powered down, connect the SDR-SDR Camera Link cable to the camera and to the frame grabber card. Take care to avoid putting undue stress on the frame grabber card. They cannot support the weight of a Camera Link cable and are susceptible to damage.
4. Power up the computer.
5. Power up the camera as described in Section 2.4 Powering the Camera for the First Time.
6. Open FrameLink Express application. If the Camera Link card is not recognized, repeat steps 1 through 4.
7. Use the View pulldown menu to open the Camera Parameters and Terminal dialogs. Use the “Learn” function to set the camera resolution, and change camera bit depth to 12. Click “Apply” and “Grab”. You should see a live image on the main window.
8. Switch to the Terminal window and change the Baud rate to 57600 (this is the factory default). You should now be able to send serial commands and receive responses.

2.3. SUI Image Analysis Freeware

Included on the minidisc is the installable freeware sample program SUI Image Analysis. Connecting to the camera with either NI MAX or FrameLink Express Application prior to using SUI Image Analysis is highly recommended.

This freeware is a sample program that works with National Instruments frame grabbers. It is a runtime using the NI base installation and connects only to specific NI and Imperx frame grabbers. Follow these steps to install SUI Image Analysis:

Install the National Instruments software and hardware prior to installing SUI-IA.

Install SUI-IA from the minidisc, as found in a subdirectory.

If using a different brand frame grabber, SUI-IA can be used in an Off-line mode only, relying on the frame grabber’s supplied software for data acquisition and storage, and importing the data if desired.

In addition to SUI Image Analysis, Camera Link Terminal, a dedicated terminal for serial communications, is provided on the minidisc. This software provides advanced serial communication functionality, such as the ability to send script files and to send command sequences repeatedly (loop test). This software can be used alongside SUI Image Analysis, NI MAX, or FrameLink Express Application.

2.4. Powering the Camera for the First Time

The CSX camera factory default configuration has the camera power on to free running (not triggered) operation with Auto Gain Control (AGC), corrections, enhancements, and other functions enabled. The exact configuration is located in Appendix B, which is included as a separate document and includes default factory settings and calibration information. It is highly recommended that the user become familiar with this document.

It is recommended that the user become familiar with toggling AGC and enhancements on/off, manually setting OPRs, and cross-referencing with the OPR tables on Appendix B. The power-up operating mode can be user-customized and saved so the camera boots to desired operating conditions, as described in Section 5.5 Configuration Commands.

The user can send serial commands directly through a terminal, or can use the GUIs provided in NI MAX and SUI Image Analysis. If using NI MAX or SUI IA, be aware that the contents of the .ICD file, including camera configuration settings, will be sent to the camera each time “Snap” or “Grab” buttons are clicked. This occurs in the background and is not obvious. This functionality can be disabled by unclicking the “Serial Commands Enabled” checkbox in NI MAX and saving the .ICD file.

The most basic user commands are shown in Table 2. Basic User Commands:

Table 2. Basic User Commands

Command	Description	Full Description
AGC:ENABLE [ON/OFF]	Toggles automatic gain control. AGC allows the camera to automatically select the most appropriate OPR for a given scene. The OPR is an operational configuration that contains integration time, nominal FPA gain, .	Section 5.9.1
AGC:ENABLE?	Returns the state of the AGC.	Section 5.9.2
OPR x	Loads an operational configuration. This includes integration time, frame time, and nominal FPA gain. See the separate Appendix B document for descriptions of individual OPRs. If AGC is on, the OPR x command will immediately be over-ridden by the AGC. Turn AGC:ENABLE OFF prior to using OPR x.	Section 5.5.3
OPR?	Returns the current OPR.	Section 5.5.4
ENH:ENABLE [ON/OFF]	Toggles the in-camera image enhancements. These should be turned off for radiometric, machine-vision, and similar applications.	Section 5.10.1
ENH:ENABLE?	Returns the state of in-camera enhancements.	Section 5.10.2

3. Camera Link Data Interface

The digital data interface to the camera is through a base Camera Link compatible interface using low-voltage differential signaling (LVDS). Sensors Unlimited cameras can be interfaced to most frame grabbers, and they have verified operation with National Instruments cards.

PoCL ‘Power over Camera Link’ is not employed and special PoCL cables are not required. However, PoCL cables are compatible.

Table 3. Digital output 26-pin connector (3M 12226-1150-00FR) signal assignment. (standard Camera Link protocol)

1	Inner shield (camera GND)	20	SerTC-
14	Inner shield (camera GND)	8	SerTFG-
2	X0-	21	SerTFG+
15	X0+	9	CC1-
3	X1-	22	CC1+
16	X1+	10	No connect
4	X2-	23	No connect
17	X2+	11	No connect
5	Xclk-	24	No connect
18	Xclk+	12	No connect
6	X3-	25	No connect
19	X3+	13	Inner shield (camera GND)
7	SerTC+	26	Inner shield (camera GND)

Table 4. Digital output ST4 board-to-board connector variant (ST4-30-1-1.50-L-D) signal assignment.

2	XCLK_N	1	X0_N
4	XCLK_P	3	X0_P
6	GND	5	GND
8	X2_N	7	X1_N
10	X2_P	9	X1_P
12	GND	11	GND
14	X3_N	13	CC1_N
16	X3_P	15	CC1_P
18	GND	17	GND
20	SER_TC_N	19	SER_TFG_N
22	SER_TC_P	21	SER_TFG_P
24	GND	23	GND
26	NC	25	NC
28	Trig_In	27	Sync_Out
30	Trig_In_RTN	29	Sync_Out_RTN
32	NC	31	NC
34	NC	33	NC
36	NC	35	NC
38	NC	37	NC
40	NC	39	NC
42	NC	41	NC
44	NC	43	NC
46	Reserved, Do not use	45	Reserved, Do not use
48	Reserved, Do not use	47	Reserved, Do not use
50	Reserved, Do not use	49	Reserved, Do not use
52	NC	51	NC
54	PWR_RTN	53	PWR_IN
56	PWR_RTN	55	PWR_IN
58	PWR_RTN	57	PWR_IN
60	PWR_RTN	59	PWR_IN

Table 5. AUX/IO 14-pin connector (3M 12214-1150-00FR) signal assignment.

1	V-	8	SYNC-RTN
2	V-	9	SYNC-OUT
3	V-	10	TRIG-IN-RTN
4	V+	11	TRIG-IN
5	V+	12	RS232-RTN
6	V+	13	RS232-TX
7	V+	14	RS232-RX

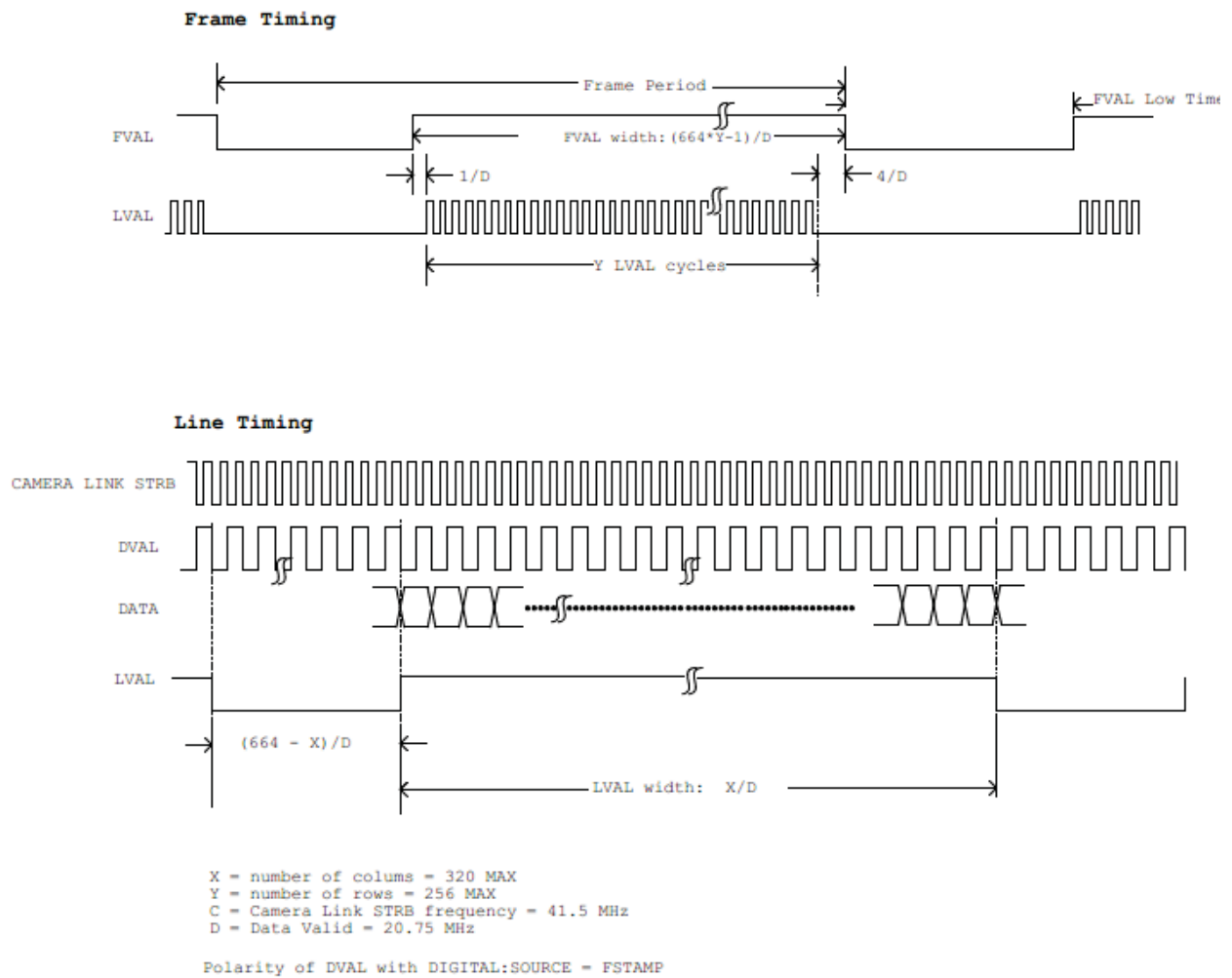

Figure 7. CSX Camera Link Timing Diagram.

4. Principles of Operation

4.1. Focal Plane Array Operation

The SUI CSX camera family uses the SU320AB4-1.7T1 Indium Gallium Arsenide (InGaAs) focal plane array (FPAs). These FPAs have 320 x 256 pixels on a 12.5 μm pitch. The FPAs consist of an InGaAs photodiode array hybridized to a CMOS readout using indium bump bonds. The photodiode array is a backside illuminated device (where light first passes through the substrate before interacting with the sensing media) with typical quantum efficiency (QE) and responsivity shown, respectively: the graphs differ by the power dependency on the wavelength of the photon. For Visible-InGaAs and NIR/SWIR, the substrate is thinned to allow shorter wavelength light to reach the light sensitive region of the photodiode. The blocking InP substrate media is removed with respect to diode operation in a separate semiconductor fabrication process. Photon detection is performed directly by the InGaAs layer in photovoltaic operation. A converting phosphor or similar layer is not used.

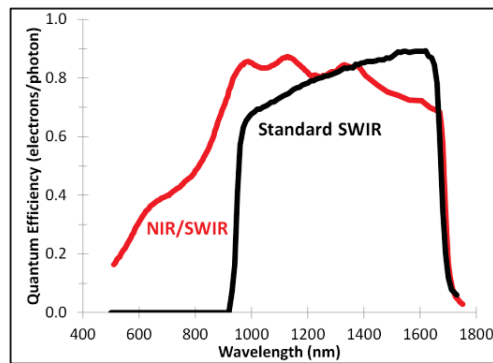

Figure 8. Typical Quantum Efficiency of SUI backside illuminated FPAs.

The CMOS readouts are “active pixel” devices in which the photocurrent is buffered, amplified and stored in each pixel. A simplified pixel schematic is shown in Figure 9. Each pixel contains a buffered gate modulated (B-GMOD) input circuit for converting current to voltage with continuously adjustable gain. In this circuit, the photodiode bias voltage is set through internally generated DSUB and VREF bias voltages. The photodiode current flows through M0 with a proportional amount of current mirrored in M1. The ratio of the currents through M1 and M0 is controlled through the externally set VBIAS and VGAIN voltages. The camera internally provides all bias voltages necessary for operation of the focal plane array.

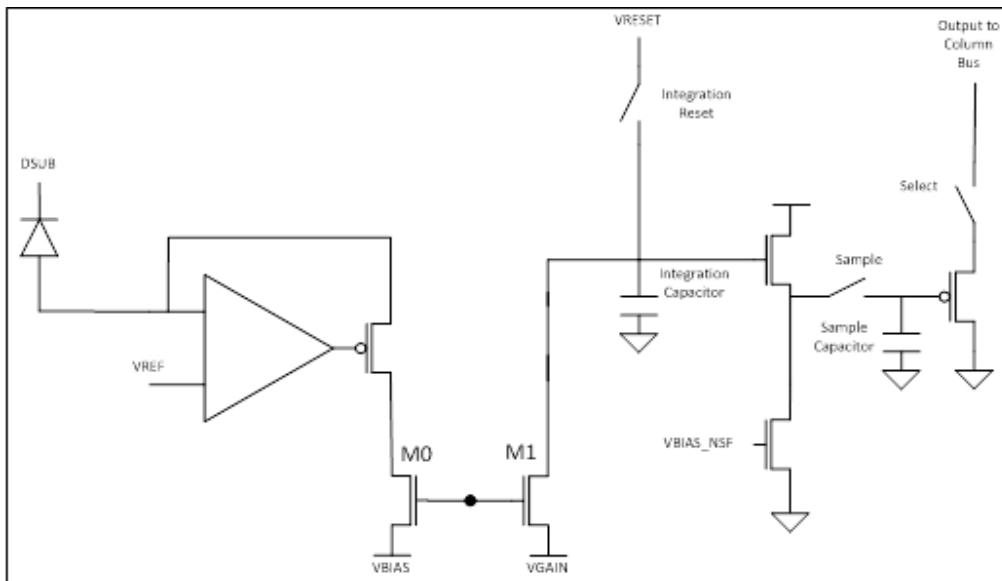

Figure 9. Simplified GMOD pixel schematic

The camera frame sequence consists of an exposure followed by digitization and readout. During exposure, the integration reset switch is open and the integration capacitor shown is discharged from its reset voltage by the mirrored photodiode current, converting the signal current to a voltage. At the end of the integration time, the sample switch is momentarily closed to sample the integration period's final signal voltage. After the signal is sampled, the integration reset switch is closed and held until the start of the next integration period. The exposure may or may not overlap the readout of the last frame depending on the exposure period and the frame rate. Since all pixel's integration reset, sample, and sample reset switches receive the same clock timing, the FPA operates with "snapshot" exposure: all pixels are exposed simultaneously, starting and finishing at the same time.

In order to generate the serial digital video signal that is output from the FPA, each row is sequentially selected, and the analog pixel signals are passed to circuitry at the edge of the array. An on-ROIC ADC converts the pixel signals to 12-bit digital values, which are then serialized and output on a high speed digital bus.

4.2. Camera System Operation

The CSX camera provides all support functions to the SU320AB4 focal plane array necessary to provide the user access to its full performance capabilities. The camera is a complete data acquisition system supporting the analog, digital, and power conditioning subsystems needed to operate the focal plane array with minimal external support, with digital taps available to grab the signal at various stages. A basic signal flow diagram for the CSX camera system is shown.

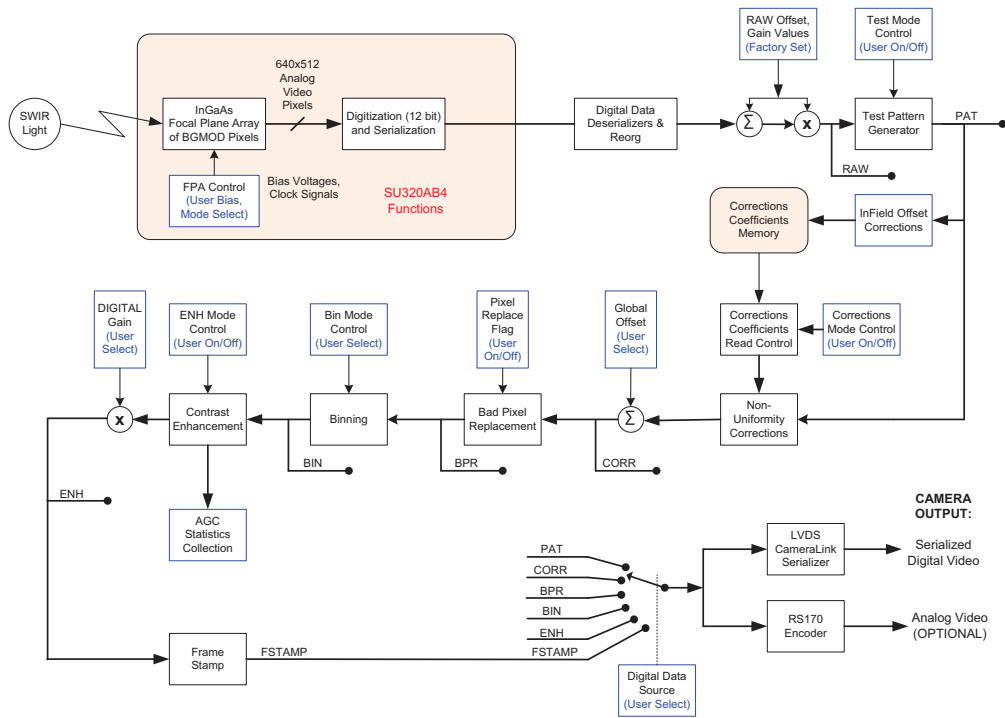

Figure 10 Camera system signal flow diagram

See the command sections for more detailed information on the operation of the various camera functions supported by the CSX camera.

5. Camera Functions and Control Software Interface

The CSX camera has a variety of features and modes that can be selected or queried through the control interface including automatic gain control (AGC), exposure time, frame rate, non-uniformity corrections, bad pixel corrections, and trigger modes. The CSX camera communicates via LVDS serial communication provisions compliant to the Camera Link standard. All camera modes are controlled using a set of ASCII commands sent by the Host to the camera utilizing the serial line inherent in the Camera Link standard.

Appendix B is included as a separate document and includes default factory settings and calibration information, including a table that correlates operational settings (OPRs) to integration time and nominal FPA gain. Appendix B is specific to each camera model. It is highly recommended that the end user become extremely familiar with this document.

5.1. Communication Protocol

The CSX camera communicates via the serial communication provisions of the Camera Link standard. This asynchronous serial communication is performed using 8 data bits, 1 stop bit, no parity, no flow control, and a configurable baud rate. (See Appendix B for the default serial communication baud rate for your particular camera.)

Table 6. Serial Communication Parameters

Serial Parameter	Default Value
Data Bits	8
Stop Bit	1
Parity	None
Flow control	None
Baud Rate	57600 factory default, user configurable.

5.2. Command Format and Response

The following typeface conventions are used when describing the camera command set:

- Text that should be reproduced literally is shown in constant-width type.
- Text that should be replaced by the user is shown in *constant-width italic type*.
- Optional text is enclosed in square brackets ([]).
- Comments are preceded by a double dash (--).
- Special operating or cautionary remarks are prefaced by Note: and *italicized in the normal font*.
- **WARNING notes are in boldface.**

When commanding the camera the following rules apply:

- Command input is not case sensitive, upper and lowercase characters are accepted by the camera.
- A carriage return <CR> ends each command.
- All commands and arguments should be separated by white space.

- Extra arguments entered on the command line will be ignored, although there is a maximum character count.
- The camera supports several echo modes. The camera can echo the received character back to the user. Alternatively, the echo mode can be configured so that every character received by the camera is echoed using a user-specified character, such as an asterisk. Finally, echo can be disabled, resulting in no output of an echo line. The commands to control the supported echo modes are discussed in the following sections
- The return value line output is command dependent. Some commands, such as query commands, will have a return value and so this line will be output. Other commands have no return value and so no return value line will be output.
- Upon successful execution of a command, the processed command response line contains the command and any valid arguments provided. Since extra invalid arguments can be entered on the command line, the processed command response may differ from the command line input (and echo line).
- Upon unsuccessful execution of a command, the processed command response line contains all arguments entered on the command line. The processed command response line output can be suppressed by setting the response mode to “brief”, and can be enabled by setting the response mode to “verbose”. Note: The processed command and any arguments returned will be separated by a single space, and will be capitalized regardless of the format in which they were originally entered on the command line. The commands to control the supported response modes are discussed in appropriate sections.
- Upon successful execution of the command, the command execution outputs the characters:
 - “OK”.

If the command failed or is invalid, the output is

 - “ERROR”.

The command execution result is always output.
- After the command execution result is returned, the camera will return the command prompt character “>.” Reception of the command prompt character by the Host is an indication that the camera is ready to receive the next command.

Table 7. Line format of camera command return strings

Line Format	Line Description	Conditions
COMMAND [<i>ARGUMENTS</i>]<CR>	Echo	Returned if configured with echo enabled. Shown format is for echo of received characters. May also be configured for return of user specified character.
[return value]<CR>	Return Value	Returned if issued command results in a return value.
COMMAND [<i>VALID ARGS</i>]<CR>	Processed Command Response	Returned if configured for verbose response mode.
RESULT<CR>	Command Result	Always returned.
>	Command Prompt	Always returned.

5.3. Startup Messaging

Reboot of the camera occurs when power to the camera is cycled. On reboot, the camera transmits a startup banner to the host. The CSX startup banner has the following format:

```
SU320CSX Camera
Sensors Unlimited, Inc. - All
Rights Reserved
Software Version
XXXX.XX.XX.XX
Hardware Version
XXXX.XX.XX.XX
>
```

Version numbers will be replaced with your actual versions.

Once the command prompt character “>” has been received by the host, the camera is ready to receive a command.

5.4. Command Set

A detailed explanation of each command is presented in the following format:

Description:	Describes the behavior of the command and other pertinent information.
Setting	Type Specifies if the command’s value is a global setting, operational setting, or neither.
Command	Command syntax.
Parameters	Lists the parameters taken by the command as listed in the syntax above.
Type	Specifies the expected type of the parameter.
Range	Specifies the valid range of the parameter.
Return Values	Lists the values returned by the command.
Example	Provides a programming example, showing the syntax of the command, parameters, and return values. For brevity these examples do not include echo, processed command response, command execution result, or command prompt.

5.5. Configuration Commands

The camera has three distinct memory spaces, shown in Camera Memory Layout figure, that are used to manage the camera’s configuration. There are two non-volatile memory spaces, one that holds the User Configuration and another behind a ‘firewall’ that holds the Factory Configuration. The User Configuration can be altered and saved by the user to customize camera operation. The Factory

Configuration, programmed at time of manufacture, cannot be altered by the user. This configuration is provided to restore the camera to its default configuration with the CONFIG:RESET command, if needed. Appendix B lists the factory global configuration setting values, and is a separate document from this manual.

A single volatile memory space is used to hold the Current Session Configuration. This memory space is changed each time the user issues a command, but this memory space does not persist between power cycles and camera reboots, only the User Configuration persists between power cycles and camera reboots.

The User Configuration is loaded into the Current Session Configuration upon camera power-up. The User Configuration can be modified by issuing the CONFIG:SAVE command, which causes the global setting in the Current Session to be written back to the User Configuration, overwriting the previous global settings. Issuing the OPR:SAVE command results in the creation of a new operational slot in the User Configuration. The present state of the operational setting in the Current Session Configuration is saved to this newly created operational slot. Issuing the OPR:UPDATE command causes the operational settings in the Current Session Configuration to be written back to the User Configuration, overwriting the previous settings for that particular operational slot.

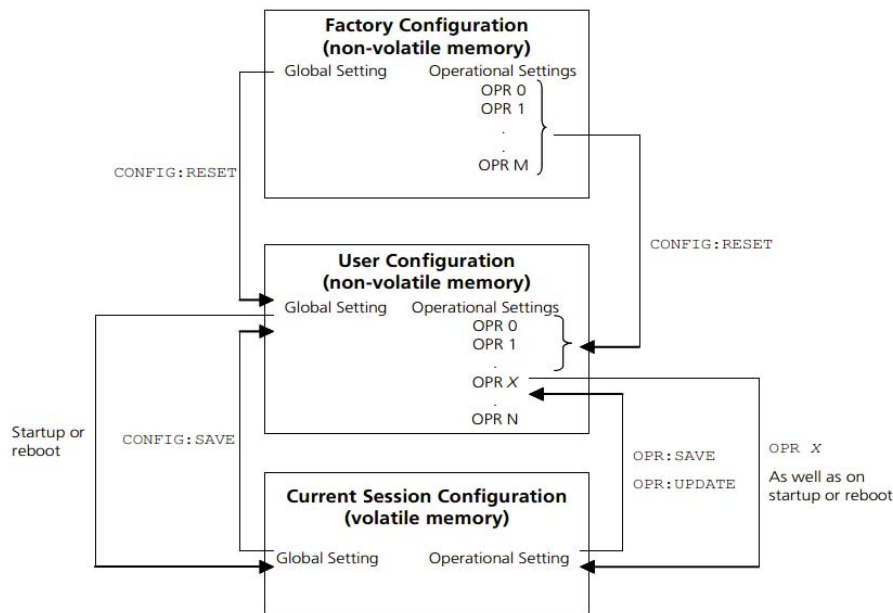

Figure 11: Camera memory layout.

Different operational settings can be loaded into the Current Session Configuration with the OPR command. Once the global and operational settings are loaded they can be modified by issuing commands to the camera. Changes to the global and operational settings will not persist between camera power cycles unless they are saved to User Configuration non-volatile memory space using the CONFIG:SAVE and OPR:SAVE or OPR:UPDATE commands.

5.5.1.Restore Factory Configuration

Description:	Restores the factory default settings. The User Configuration memory space is erased. Then the Factory Configuration is copied to the User Configuration memory space. Finally, the Current Session Configuration is reloaded from the User Configuration. Most modifications made by the user will be lost. However, offset correction values overwritten with CORR:OFFSET:CAL will persist. Appendix B (separate document) lists the Factory Configuration global and operational parameter values for your camera model.
Setting Type	N/A
Command	CONFIG:RESET
Parameters	None
Return Values	None
Example	None
	CONFIG:RESET

5.5.2.Save Global Configuration

Description:	Overwrites the User Configuration global settings with the Current Session's global settings.
Setting Type	N/A
Command	CONFIG:SAVE
Parameters	none
Return Values	none
Example	CONFIG:SAVE

5.5.3.Load Operational Configuration

Description:	Loads the operational settings for the specified operational slot. See the separate Appendix B document for a table of OPR settings and corresponding integration and nominal FPA gain settings. An error will occur if an opr_number outside of the available range is used.
Setting Type	N/A
Command	OPR opr_number
Parameters	opr_number
Return Values	none
Range	0 to N (limited by the number of operational settings that currently exist, see the separate Appendix B document for table of OPR settings).
Type	unsigned integer

Example OPR 5

5.5.4. Get Current Operational Configuration Number

Description	Returns the current operational slot number that is loaded.	
Setting Type	N/A	
Command	OPR?	
Parameters	none	
Return Values	opr_number	
Range	0 to N, maximum value N is OPR:MAX (see command below).	
Type	unsigned integer	
Example	OPR?	-- query command
	5	-- return value

5.5.5. Get Total Number of Operational Configurations

Description	Returns the number of operational settings currently present in the User Configuration memory.	
Setting Type	N/A	
Command	OPR:MAX?	
Parameters	none	
Return Values	number	
Range	1 to N	
Type	unsigned integer	
Example	OPR:MAX?	-- query command
	8	-- return value

5.5.6. Set Startup Operational Configuration

Description	Sets the operational slot number that will be loaded on reboot of the camera. Note: Because this is a global setting, a CONFIG:SAVE command must subsequently be issued to cause any changes in this value to be saved to the User Configuration memory. Because the number of OPRs can change by user action, it is possible to set this parameter to an invalid OPR.	
Setting Type	Global	
Command	OPR:START <i>opr_number</i>	
Parameters	<i>opr_number</i>	
Return Values	none	

Range	0 to N, maximum value limited by the number of operational settings that currently exist.
Type	unsigned integer
Example	OPR:START 5

5.5.7. Get Startup Operational Configuration

Description	Returns the operational slot number that will be loaded on reboot of the camera.	
Setting Type	Global	
Command	OPR:START?	
Parameters	none	
Return Values	opr_number	
Range	0 to N', maximum value limited by the number of operational settings that once existed.	
Type	unsigned integer	
Example	OPR:START?	-- query command
	5	-- return value

5.5.8. Create New Operational Configuration

Description	<p>Takes the Current Session operational setting and saves it to the User Configuration memory assigning a new operational slot number. The operational slot numbers are assigned sequentially. The new operational slot number will be returned to the host. The OPR:SAVE command will return an error for camera models where all available OPR memory slots are populated by factory configured OPR parameters. Note: When a new operational setting is created, any factory correction table associated with the current operational slot will not be copied to the new operational slot setting. Corrections, therefore, must be disabled when using the newly created configuration slot for meaningful data to be produced. This command is only required when users require custom OPR settings.</p>	
Setting Type	N/A	
Command	OPR:SAVE	
Parameters	none	
Return Values	newly created opr_number	
Range	0 to N	
Type	unsigned integer	
Example	OPR:SAVE	-- command
	18	-- return value

5.5.9. Update Existing Operational Configuration

Description	Takes the Current Session operational setting and saves it to the User Configuration memory in the selected OPR slot. This command is only required when users require custom OPR settings.
Setting Type	N/A
Command	OPR:UPDATE
Parameters	none
Return Values	none
Range	
Type	
Example	OPR:UPDATE

5.5.10. Delete Last Operational Configuration

Description	Deletes the last, or highest slot number, operational configuration slot from the User Configuration memory. This operation will only delete operational configuration slots created by the user, and will return an error if executed when only factory operational configuration slots exist. If the Current Session Configuration is the last operational configuration when this command is issued, a subsequent query of the current operational configuration number will return the deleted operational configuration number, since it is still the Current Session Configuration, but a command to load the deleted operational number will error. WARNING: If the startup operational configuration slot is deleted, the camera startup operation is no longer specified. Use the OPR:START followed by the CONFIG:SAVE commands to reselect an existing operational configuration slot if the startup operational configuration slot is deleted.
Setting Type	N/A
Command	OPR:DEL
Parameters	none
Return Values	none
Range	
Type	
Example	OPR:DEL

5.5.11. Delete All Operational Configurations

Description	Deletes all operational configuration slots created by the user from
-------------	--

the User Configuration memory. This operation will return an error if executed when only factory operational configuration slots exist. If the Current Session Configuration slot is deleted from the User Configuration memory, a subsequent query of the current session operational configuration slot number will return the deleted operational configuration slot number, since it is still the Current Session Configuration, but a command to load the deleted operational configuration slot number will return an error. **WARNING:** If the startup operational configuration slot is deleted, the camera startup operation is no longer specified. Use the OPR:START followed by the CONFIG:SAVE commands to reselect an existing operational configuration slot if the startup operational configuration slot is deleted.

Setting Type	N/A
Command	OPR:DEL:ALL
Parameters	none
Return Values	none
Range	
Type	
Example	OPR:DEL:ALL

5.6. Serial Communication Interface Commands

Baud rate configuration in the volatile memory space is managed with two discrete variables. The first variable, current baud rate, represents the baud rate at which the camera is currently communicating. The second variable, future baud rate, holds the baud rate value that will be stored to non-volatile memory when a global configuration save (CONFIG:SAVE) is executed. Changing the current baud rate will require the host to change baud rates for communication to continue. Changing the future baud rate and saving it to non-volatile memory allows for the new baud rate to be effective upon reboot of the camera. The factory default is 57600 baud. Other serial communication parameters are located in Table 6.

5.6.1. Set Current Baud Rate

Description	This command updates the current baud rate variable. The baud rate that the camera communicates at will change immediately. WARNING: Changing the current baud rate will require the host to change baud rates for communication to continue.
Setting Type	Global
Command	BAUD:CURRENT <i>baud_rate</i>
Parameters	<i>baud_rate</i>
Return Values	none
Range	57600

	115200
	230400
	460800
Type	unsigned integer
Example	BAUD:CURRENT 57600

5.6.2. Get Current Baud Rate

Description	Returns the current baud rate.	
Setting Type	Global	
Command	BAUD:CURRENT?	
Parameters	none	
Return Values	baud_rate	
Range	57600	
	115200	
	230400	
	460800	
Type	unsigned integer	
Example	BAUD:CURRENT?	-- query command
	57600	-- return value

5.6.3. Set Future Baud Rate

Description	Updates the future baud rate variable. WARNING: A CONFIG:SAVE command must be executed after this command for a change in the future baud rate value to be saved and persist after power cycle.	
Setting Type	Global	
Command	BAUD:FUTURE <i>baud_rate</i>	
Parameters	<i>baud_rate</i>	
Return Values	none	
Range	57600	
	115200	
	230400	
	460800	

Type unsigned integer
 Example BAUD:FUTURE 230400

5.6.4. Get Future Baud Rate

Description Returns the value stored in the future baud rate variable.
 Setting Type Global
 Command BAUD:FUTURE?
 Parameters none
 Return Values baud_rate
 Range 57600
 115200
 230400
 460800

Type unsigned integer
 Example BAUD:FUTURE? -- query command
 230400 -- return value

5.6.5. Set Echo Mode

Description Sets the echo mode for serial communications. In mode 0 echo is disabled. In mode 1 echo is enabled. Any character received on the serial port is immediately echoed back. An exception to the echo of the received character with mode 1 enabled is when a backspace character is received while the receive buffer is empty. In mode 2 echo is enabled but instead of echoing back the character received a user defined character is echoed. Echo mode 1 provides for the most robust communication, allowing the host to verify that each character sent to the camera was properly received. Echo mode 2 allows the host to verify that the camera received characters, but does not provide a way to verify that characters were not corrupted during transmission.

Setting Type Global
 Command ECHO:MODE mode
 Parameters *mode*
 Return Values none
 Range 0 Echo off
 1 Echo received character

2 Echo user defined character

Type unsigned integer
 Example ECHO:MODE 1 -- query command

5.6.6. Get Echo Mode

Description Returns the current echo mode setting.
 Setting Type Global
 Command ECHO:MODE?
 Parameters none
 Return Values mode
 Range
 0 Echo off
 1 Echo received character
 2 Echo user defined character

Type unsigned integer
 Example ECHO:MODE? -- query command
 1 -- return value

5.6.7. Set Echo Character

Description Sets the echo character returned when in echo mode 2. The character is set by entering the ASCII code of the desired character
 Setting Type Global
 Command ECHO:CHAR *value*
 Parameters *value*
 Return Values none
 Range 0 to 255
 Type unsigned integer
 Example ECHO:CHAR 35 -- ASCII CODE 35 is #

5.6.8. Get Echo Character

Description Returns the echo character used for echo mode 2.
 Setting Type Global

Command	ECHO:CHAR?
Parameters	none
Return Values	value
Range	0 to 255
Type	unsigned integer
Example	ECHO:CHAR? -- query command 35 -- return value

5.6.9. Set Response Mode

Description	The camera supports two response modes, brief and verbose. In verbose response mode the processed command response line discussed in Section 5.2 is output. In brief response mode the processed command response line is not echoed.	
Setting Type	Global	
Command	RESPONSE <i>mode</i>	
Parameters	<i>mode</i>	
Return Values	none	
Range	BRIEF	Brief response mode
	VERBOSE	Verbose response mode
Type	string	
Example	RESPONSE VERBOSE	

5.7. Non-Uniformity Corrections (NUCs) Commands

The factory operational configuration slots (OPRs) support two-point correction tables that can be used to compensate for the dark signal and photoresponse non-uniformity of the FPA. The gain and offset correction coefficients are unique for each operational setting. The correction table coefficients are applied to create a corrected pixel value PIXCORR according to the following relation:

$$\text{PIXCORR} = ((\text{PIXIN} - \text{CORROFF}) \times \text{CORRGAIN} / 2048) + \text{GLOBALCORROFF}$$

where PIXIN is the raw pixel value, CORROFF is the offset correction value, CORRGAIN is the gain correction value, and GLOBALCORROFF is the global corrected offset value. CORROFF and CORRGAIN are unique for each FPA pixel and operational configuration slot. GLOBALCORROFF is applied to every pixel of the frame. The correction commands allow the offset, gain, and pixel corrections

to be independently enabled or disabled. If offset correction is disabled, CORROFF and GLOBALCORROFF are 0. If gain correction is disabled, CORRGAIN is 2048.

If either gain or offset correction is applied to the raw pixel data and a subsequent digital fixed gain of 1X is used, some pixel values may not saturate at the full 12-bit resolution count value of 4,095. A fixed digital gain greater than 1X can be applied to the corrected image data to guarantee that all pixels saturate at the full scale value of 4,095 if needed or desirable.

5.7.1.Set Gain Correction State

Description	Sets the state of the gain correction. Gain correction compensates for pixel-to-pixel photoresponse non-uniformity. Otherwise known as a white balance correction (multiplication).
Setting Type	Global
Command	CORR:GAIN <i>state</i>
Parameters	<i>state</i>
Return Values	none
Range	ON Enables Gain Corrections OFF Disables Gain Corrections
Type	string
Example	CORR:GAIN ON

5.7.2.Get Gain Correction State

Description	Returns the state of the gain correction.
Setting Type	Global
Command	CORR:GAIN?
Parameters	none
Return Values	state
Range	ON Gain Correction Enabled OFF Gain Correction Disabled
Type	string
Example	CORR:GAIN? -- query command ON -- return value

5.7.3.Set Offset Correction State

Description	Sets the state of the offset correction. Offset correction compensates for dark current signal non-uniformity. Otherwise known as a Dark
-------------	--

	Correction (subtraction).
Setting Type	Global
Command	CORR:OFFSET <i>state</i>
Parameters	<i>state</i>
Return Values	none
Range	ON Enables Offset Corrections OFF Disables Offset Corrections
Type	string
Example	CORR:OFFSET ON

5.7.4. Get Offset Correction State

Description	Returns the state of the offset correction.
Setting Type	Global
Command	CORR:OFFSET?
Parameters	none
Return Values	state
Range	ON Offset Correction Enabled OFF Offset Correction Disabled
Type	string
Example	CORR:OFFSET? -- query command ON -- return value

5.7.5. Set Global Corrected Offset Value

Description	Sets the global corrected offset value. Global offset is a fixed value that is added to each pixel in the image after all other corrections have been applied if offset correction is enabled. The net effect of this command is a positive DC offset. As this command is after the RAW ADC step, any negative raw pixel value going into the ADC is not offset and remains zero-clipped (an unusual condition to begin with). The global offset can be disabled by setting its value to zero.
Setting Type	Global
Command	CORR:OFFSET:GLOBAL <i>value</i>
Parameters	<i>value</i>

Return Values	none
Range	0 to 4095
Type	unsigned integer
Example	CORR:OFFSET:GLOBAL 0

5.7.6. Get Global Corrected Offset Value

Description	Returns the global corrected offset value.
Setting Type	Global
Command	CORR:OFFSET:GLOBAL?
Parameters	none
Return Values	value
Range	0 to 4095
Type	unsigned integer
Example	CORR:OFFSET:GLOBAL? -- query command 0 -- return value

5.8. Bad Pixel Corrections

Defective FPA pixels can be substituted with an interpolated pixel value. The pixel correction function uses a bad pixel map that is unique to each operational configuration slot (OPR).

A command to enable the return of the correction pixel map in the form of image data is supported. When the correction pixel map is enabled, a pixel value of 0 is returned for pixels locations that are not replaced and 4,095 returned for pixels that are replaced when pixel correction is enabled.

5.8.1. Set Pixel Substitution State

Description	Sets the state of the pixel substitution. Pixel substitution replaces pixels that do not pass focal plane array performance specifications with the last, non-replaced pixel value. Consecutive substitution is allowed, using the same non-replaced pixel value. While more pleasing to the eye/brain, some machine vision computations perform better with pixel substitution off.
Setting Type	Global
Command	CORR:PIXEL <i>state</i>
Parameters	<i>state</i>
Return Values	none
Range	ON Enables Pixel Substitutions OFF Disables Pixel Substitutions
Type	string

Example CORR:PIXEL ON

5.8.2. Get Pixel Substitution State

Description	Returns the state of the pixel substitution.
Setting Type	Global
Command	CORR:PIXEL?
Parameters	none
Return Values	state
Range	ON Pixel Substitution Enabled OFF Pixel Substitution Disabled
Type	string
Example	CORR:PIXEL? -- query command ON -- return value

5.8.3. User Pixel Defect Flag

Description	<p>Allows the user to add a pixel into the defective pixel map, allowing the pixel correction tool CORR:PIXEL to act on these additional individual pixels. Pixels may be defined in the current OPR or defined for all OPRs.</p> <p>Pixels are selected by their X,Y coordinates in each OPR, and can be interactively added and removed from the map. Additionally, the command can be used to turn the individual x,y user-added pixels ON or OFF across all OPRs.</p>
Setting Type	Global
Command	PIX:RPL <i>parameters</i>
Parameters	<i>x, y ordinates of pixel, ON/OFF, ALL</i>
Return Values	
Range	<p><x> X coordinate of selected pixel</p> <p><y> Y coordinate of selected pixel</p> <p>ON <default> Flags pixel for replacement</p> <p>OFF Removes flag to make pixel active</p> <p>ALL Sets ON or OFF state to user-flagged pixels across all OPRs</p>
Type	integer, string

Example	Examples PIX:RPL 34 127 ON --Sets pixel (34,127) to replacement status PIX:RPL 34 127 OFF ALL --Restores flagged pixel 34,127 in all OPRs to active PIX:RPL 34 127 --Sets pixel (34,127) to replacement status (ON) in current OPR
---------	--

5.8.4. User Pixel Defect Flag Count

Description	Counts the number of pixels currently enabled in User Pixel Replacement (PIX:RPL)
Setting Type	Global
Command	PIX:BAD?
Parameters	none
Return Values	integer
Range	0 - n
Type	n/a
Example	PIX:BAD? -- query command 7 -- return value (7 user-defined pixels)

5.8.5. Set Correction Bypass State

Description	Sets the state of the correction bypass: With one command the 3 correction commands: Gain (white), Offset (dark) and Pixel (defect) Correction are set to On or Off as a group.
Setting Type	Global
Command	CORR:BYPASS <i>state</i>
Parameters	<i>state</i>
Return Values	none
Range	ON Enables Correction Bypass OFF Disables Correction Bypass
Type	string
Example	CORR:BYPASS ON

5.8.6. Get Correction Bypass State

Description	Returns the state of the correction bypass.
Setting Type	Global

Command	CORR:BYPASS?
Parameters	none
Return Values	state
Range	ON Corrections globally bypassed OFF Corrections not globally bypassed
Type	string
Example	CORR:BYPASS? -- query command ON -- return value

5.8.7. Set Pixel Substitution Map State

Description	Sets the state of the pixel substitution map. If enabled, a pixel value of 0 is returned for pixels locations that are live (not replaced) and 4,095 is returned for pixels that are replaced when pixel substitution is enabled (marked defective pixel). The result is essentially Binary in the outputted image: black for valid pixels, and white for substitute locations, in an image format, which makes it easy for image math or to generate a CSV file of substitute locations. This tool will disconnect the prior data flow stream, so it is not possible to act on this map.
Setting Type	Global
Command	CORR:PIXEL:MAP <i>state</i>
Parameters	<i>state</i>
Return Values	none
Range	ON Enables Pixel Substitution Map OFF Disables Pixel Substitution Map
Type	string
Example	CORR:PIXEL:MAP OFF

5.8.8. Get Pixel Substitution Map State

Description	Returns the state of the pixel substitution map.
Setting Type	Global
Command	CORR:PIXEL:MAP?
Parameters	none
Return Values	state

Range	ON	Pixel Substitution Map Enabled
	OFF	Pixel Substitution Map Disabled
Type	string	
Example	CORR:PIXEL:MAP? -- query command OFF -- return value	

5.8.9. Perform In-Field Dark Offset Operation

This command will perform an offset correction that is stored in camera RAM memory (volatile) for a single OPR setting, or stored to camera flash (nonvolatile) for ongoing use. This is also referred to as an In-Field Dark Offset Correction (IFOC). This function only affects the NUC offset (CORROFFSET as described in Section 5.7).

Preconditions:

- 1) The AGC must be disabled (AGC:ENABLE OFF) when running the In-Field Dark Offset Correction function.
- 2) The scene must be dark, else the resulting non-dark-recorded offset will act like a mask or watermark superimposed on the live video data. Zero clipping may also be possible after the IFOC is carried out if any light is present at the FPA.

The camera can store the resulting correction frame in camera volatile memory for temporary correction conditions that do not persist a power cycle, or the data may be written to Flash non-volatile memory for semi-permanent use (i.e. persist power cycle, but change the next time this command is operated). **Once overwritten, the use of a CONFIG:RESET command will not restore the original factory values.**

The IFOC function sums and averages 32 or 64 frames to average the noise response by root(# of frames). Noise is decreased by ~5 or ~8 x in this manner, respectively. More importantly is that it prevents a single noise spectrum from being superimposed on the newly created NUC table. At normal frame rates of 30 fps, the offset data is collected in roughly 1 or 2 seconds. If a custom FRAME:PERIOD value is used, the time for acquisition is the EXP time multiplied by either 32 or 64, depending on the value of the *<frames>* argument.

The camera has been designed to recover from power interruptions during flash write operations. The camera will start up normally, but it may be necessary to re-run the offset calibrations command to fix a potentially-corrupted correction.

Description	Perform offset calibration operation.	
Setting Type	N/A	
Command	CORR:OFFSET:CAL <i>arguments</i>	
Parameters	<i>arguments: <frames> <flash> <output></i>	
Return Values	none	
Range	32	Initiates an averaging of 32 frames of field offset

calibration data where the accumulated value for each pixel replaces the factory offset corrected pixel value. The data is collected for the currently selected OPR and timing mode. Once accumulated, this data will then start to be used to apply offset correction to the pixel data for the OPR that was used when it was collected.

It is intended for the user to inhibit light from falling on the FPA for the duration of the command execution: For normal OPR operations, 32 frames at 30 fps is roughly 1 second.

64 Initiates an averaging of 64 frames of field offset calibration data where the accumulated value for each pixel replaces the factory offset corrected pixel value. The data is collected for the currently selected OPR and timing mode. Once accumulated, this data will then start to be used to apply offset correction to the pixel data for the OPR that was used when it was collected.

It is intended for the user to inhibit light from falling on the FPA for the duration of the command execution: For normal OPR operations, 64 frames at 30 fps is roughly 2 seconds.

FLASH Optional. If FLASH is not specified, the camera accumulates and stores the offset data in camera memory for use in the current OPR. The data is held until power is cycled/reboot. The new offset correction will be available if you leave and return to the given OPR.

If FLASH is specified, on completion of the frame collections, the camera will then write the new correction data to camera flash (nonvolatile) memory, which survives camera reboots.

OUTPUT Provides a countdown of the flash write activity, parsed at reasonable intervals. While possibly helpful in monitoring the flash write process, OUTPUT does not time the actual acquisition of frames. Typical time for FLASH operations to complete can be as long as 4 seconds. The OUTPUT command use does not change the operation length of the FLASH update. Invoking OUTPUT without FLASH adds no value.

Type string

Example
 CORR:OFFSET:CAL 32 FLASH OUTPUT
 -- acquire cal offset data based on 32 frames and write to camera nonvolatile memory while metering the flash write process.
 CORR:OFFSET:CAL 64
 -- acquire cal offset data based on 64 frames and save in camera live (volatile) memory.

CORR:OFFSET:CAL

-- acquire cal offset data based on 32 (default value) frames and save in camera live (volatile) memory.

5.9. Automatic Gain Control (AGC) Commands

The Automatic Gain Control (AGC) algorithm monitors frame statistics on every frame and selects the operational configuration (OPR number) to achieve the best camera sensitivity settings for the given imaging scene. When AGC is enabled, operational configurations can be loaded using the OPR command (Section 5.5.3). However, the AGC algorithm will override the user set operation configuration if the scene data falls outside of the AGC requirements for that OPR. Therefore, it is best to disable the AGC when manually adjusting the operational configuration (OPR). The OPR? command can be used to poll the current operational configuration setting.

The AGC operates within groups of OPRs of a related temperature setpoint. These OPR groups are delimited by the Macro group. See the separate Appendix B document for a table of OPRs and details on the MACRO command settings. See Section 5.20 for details on the MACRO command itself.

TEC Setpoint (°C)	MACRO	Low Case Temperature (°C)	High Case Temperature (°C)
18	0	-40	35
32	1	0	55
45	2	20	70

For the standard configuration, there are more than one focal plane array setpoint temperatures available for AGC operation, as shown in the table above. By default, the camera loads MACRO0, which corresponds to the lowest FPA setpoint. This allows for the highest sensitivity operation, but may also show image persistence in certain scenes. If the case temperature is expected to exceed 35°C, or if image persistence is an issue, it is best to run MACRO1, which utilizes the median focal plane array temperature setpoint for standard sensitivity with low lag (image persistence) performance. If the camera case temperature is expected to exceed 55°C, it is recommended to change the focal plane array setpoint to the high temperature AGC setting with MACRO2 to assure thermal stability of the focal plane array for elevated camera case temperatures.

The user can select among the different AGC ranges by using the MACRO command as described in Section 5.20. Macros are created by the factory and listed in Appendix B (attached on hard copy of manual, and located as a separate file on the CD shipped with your camera).

Note: The image enhancement algorithm is not recommended for windowing operation or enhancement of uncorrected data.

Note: When AGC is disabled the camera will remain in the last OPR used by the auto gain control. Turning AGC off may change the image data. This is a result of proprietary enhancement modes supported when AGC is enabled that are not supported when manually changing OPRs.

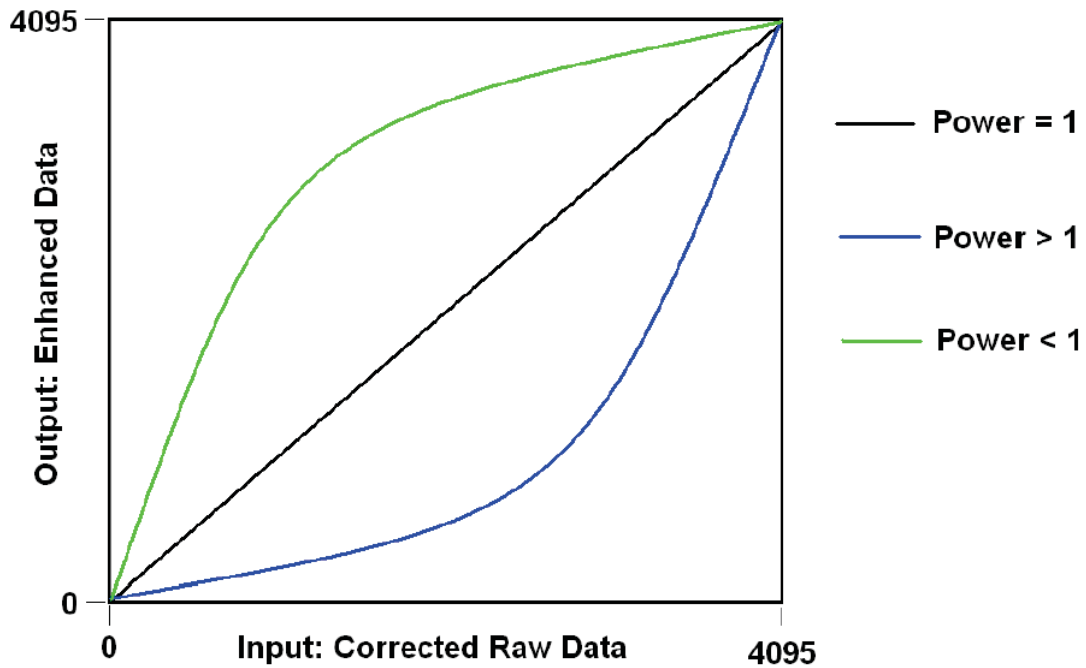

Figure 12 Effects of POWER function on look-up table and enhancements.

5.9.1.Set AGC State

Description	Sets the state of the AGC algorithm.
Setting Type	Global
Command	AGC:ENABLE <i>state</i>
Parameters	<i>state</i>
Return Values	none
Range	ON Enables AGC OFF Disables AGC
Type	string
Example	AGC:ENABLE ON

5.9.2. Get AGC State

Description	Returns the state of the AGC algorithm.
Setting Type	Global
Command	AGC:ENABLE?
Parameters	none
Return Values	state
Range	ON AGC enabled OFF AGC disabled
Type	string
Example	AGC:ENABLE? -- query command ON -- return value

5.9.3. Set AGC Low Operational Setting

Description	This command used in conjunction with the set AGC high operational setting defines the range of operational settings that are available for use by the AGC algorithm. In this tool, low refers to the numerical value, i.e. 2 is lower than 3, and is not relative to light levels. WARNING: If the AGC low operational bound is set higher than the current AGC high operational bound, the camera AGC operation is no longer specified.
Setting Type	Global
Command	AGC:OPR:LOW <i>opr_setting</i>
Parameters	<i>opr_setting</i>
Return Values	none
Range	0 to (number), limited by number of operational settings that currently exist.
Type	unsigned integer
Example	AGC:OPR:LOW 0

5.9.4. Get AGC Low Operational Setting

Description	Returns the lowest operational setting available for use by the AGC algorithm.
Setting Type	Global
Command	AGC:OPR:LOW?
Parameters	none

Return Values	opr_setting
Range	0 to (number)
Type	unsigned integer
Example	AGC:OPR:LOW? -- query command 0 -- return value

5.9.5. Set AGC High Operational Setting

Description	This command used in conjunction with the set AGC low operational setting defines the range of operational settings that are available for use by the AGC algorithm. In this tool, high refers to the numerical value, i.e. 5 is higher than 4, and is not relative to light levels. WARNING: If the AGC high operational bound is set lower than the current AGC low operational bound, the camera AGC operation is no longer specified.
Setting Type	Global
Command	AGC:OPR:HIG <i>opr_setting</i>
Parameters	<i>opr_setting</i>
Return Values	none
Range	0 to (number), limited by number of operational settings that currently exist.
Type	unsigned integer
Example	AGC:OPR:HIG 14

5.9.6. Get AGC High Operational Setting

Description	Returns the highest operational setting available for use by the AGC algorithm
Setting Type	Global
Command	AGC:OPR:HIG?
Parameters	none
Return Values	opr_setting
Range	0 to (number) limited by number of operational settings that currently exist.
Type	unsigned integer
Example	AGC:OPR:HIG? -- query command 7 -- return value

5.10. Image Enhancement Commands

The image enhancement algorithm of the CSX, when enabled, performs an enhancement on each pixel of the frame to produce a higher contrast image for display. The enhancement look-up table for each frame is computed using the previous frame’s statistics. The frame statistics used to determine the enhancement look-up table are based on a histogram of the frame’s pixels, e.g., the distribution of the frame’s pixel values. The enhancement look-up table is generated from the collected histogram by a proprietary enhancement algorithm. By applying this enhancement algorithm, the pixel data will be stretched over the available pixel bit depth resulting in a higher contrast scene for display.

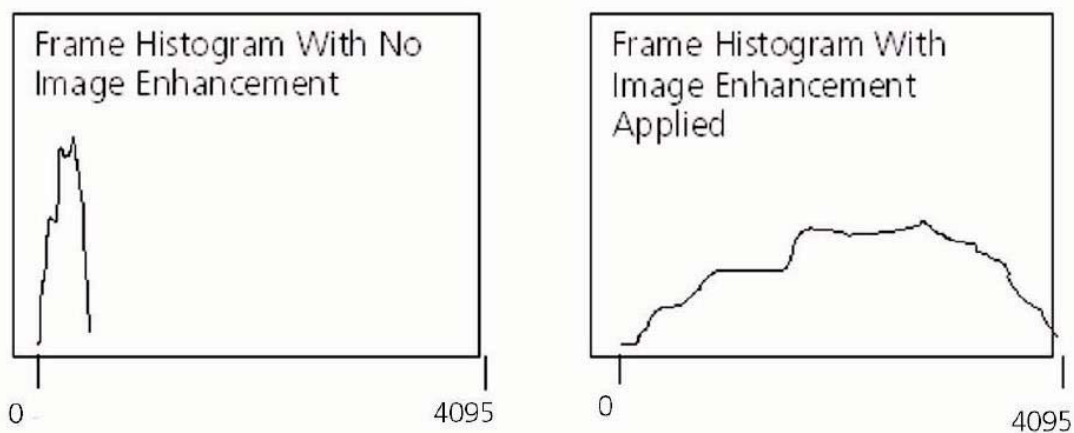

Figure 13 Example of enhancement algorithm effect on frame histogram.

When the camera is in the state ENH:AUTO ON (default), enhancements will be automatically controlled by the camera. To manually control the enhancements the command ENH:AUTO OFF should be sent and the ENH:POWER command should be used to adjust the image. The ENH:POWER function will only affect the data when ENH:AUTO is OFF and ENH:ENABLE is ON.

An ENH:POWER decimal value of less than 1 will shape the look-up table in a manner similar to the green line shown in the Figure. The slope of the curve is greater for the lower input values and will stretch the lower intensity data over a larger portion of the output, resulting in more shadow detail in the image at the expense of reducing contrast in the brighter areas of the scene.

An ENH:POWER decimal value of greater than 1 will shape the look-up table in a manner similar to the blue line shown in the Figure. The slope of the curve is greater for the higher input values and will stretch the higher intensity data over a larger portion of the output, resulting in more detail in the brighter areas of the image at the expense of reducing contrast in the lower signal (shadow) areas of the scene.

An ENH:POWER decimal value of 1 will shape the look-up table in a manner similar to the black line shown in the Figure. The slope of the curve is constant for the input values and will result in an image where the bright and dark areas of the scene are evenly weighed.

5.10.1. Set Enhancement State

Description	Sets the state of the image enhancement algorithm.
-------------	--

Setting Type	Global
Command	ENH:ENABLE <i>state</i>
Parameters	<i>state</i>
Return Values	none
Range	ON Enables Enhancements OFF Disables Enhancements
Type	string
Example	ENH:ENABLE ON

5.10.2. Get Enhancement State

Description	Returns the state of the image enhancement algorithm.
Setting Type	Global
Command	ENH:ENABLE?
Parameters	none
Return Values	state
Range	ON Enhancements Enabled OFF Enhancements Disabled
Type	string
Example	ENH:ENABLE? -- query command ON -- return value

5.10.3. Set Automatic Enhancement State

Description	Sets the state of the image enhancement algorithm to be controlled automatically (ON), or manually (OFF).
Setting Type	Global
Command	ENH:AUTO <i>state</i>
Parameters	<i>state</i>
Return Values	none
Range	ON Enables Automatic Enhancements OFF Disables Automatic Enhancements
Type	string
Example	ENH:AUTO ON

5.10.4. Get Automatic Enhancement State

Description	Returns the state of the image enhancement algorithm.
Setting Type	Global
Command	ENH:AUTO?
Parameters	none
Return Values	state
Range	ON Automatic Enhancements Enabled OFF Automatic Enhancements Disabled (Manual Enhancements Enabled)
Type	string
Example	ENH:AUTO? -- query command ON -- return value

5.10.5. Set Enhancement/AGC Frame Average and Width Weight

Description	Sets the number of frames over which frame statistics are calculated. The number of frames to be averaged is 2N.
Setting Type	Global
Command	ENH:AVG <i>value</i>
Parameters	<i>value</i>
Return Values	none
Range	0 to 5
Type	unsigned integer
Example	ENH:AVG 0

5.10.6. Get Enhancement/AGC Frame Average Weight

Description	Gets the number of frames over which frame statistics are calculated.
Setting Type	Global
Command	ENH:AVG?
Parameters	none
Return Values	value
Range	0 to 5
Type	unsigned integer
Example	ENH:AVG? -- query command 0 -- response

5.10.7. Set Enhancement Power Function

Description	Sets the power function value for manual enhancement mode. This function only affects data when in manual enhancement mode (ENH:AUTO OFF) with enhancements turned on (ENH:ENABLE ON). See Section 5.10 for a full description.
Setting Type	Global
Command	ENH:POWER <i>value</i>
Parameters	<i>value</i>
Return Values	none
Range	0 to 10
Type	unsigned decimal
Example	ENH:POWER 0.6

5.10.8. Get Enhancement Power Function

Description	Gets the power function value for manual enhancement mode.
Setting Type	Global
Command	ENH:POWER?
Parameters	none
Return Values	value
Range	0 to 10
Type	unsigned decimal
Example	ENH:POWER? -- query command 0.6 -- return value

5.11. Pixel Clock Commands

The camera electronics are designed to support a variety of focal plane arrays with varying requirements for pixel clock rate. The pixel clock is operated for the supported focal plane array at the maximum pixel clock rate reported through the command interface. The pixel clock period is needed to calculate exposure and frame times. Period is defined as the length of time for a given frequency event to occur i.e. 1 clock period (s) is 1/clock frequency (Hz).

5.11.1. Get Pixel Clock Maximum Rate

Description	Returns the FPA pixel clock rate in Hertz. The CSX camera clock rate is 20750000 Hz (20.75MHz).
Setting Type	Global

Command	PIXCLK:MAX?
Parameters	none
Return Values	value
Range	0 to 4294967295 (4,294,967,295)
Type	unsigned integer
Example	PIXCLK:MAX? -- query command 20750000 -- return value

5.12. Frame and Exposure Control Commands

The internally timed exposure period in seconds is given by the following relation:

$$\text{EXPPERIOD} = (\text{EXP} + 28) / (\text{PIXCLK:MAX}) \text{ (seconds)}$$

Where PIXCLK:MAX returns 20750000Hz (20.75MHz) and where EXP is a clock count parameter set using the EXP command. 28 clock cycles are added to the exposure setting value to produce the true exposure duration to account for clocking overheads of the FPA. The maximum exposure time for a particular frame period is equal to the frame period, less the FPA required minimum dead (non-integration) time of two row read times for the CSX.

30 μs is the absolute minimum recommended integration time, and 200 μs is the suggested minimum integration time.

The internally timed frame period is given by:

$$\text{FRAMEPERIOD} = \text{FRAME:PERIOD} / \text{PIXCLK:MAX} \text{ (seconds)}$$

The exposure period and frame period specified must be compatible with each other or a command error will occur. Therefore, knowledge of the current exposure and frame periods are required and the order in which the exposure and frame period are changed is crucial for success. Going from a short exposure and frame period to a longer exposure and frame period requires first increasing the frame period and then the exposure period, while going in the opposite direction requires shortening the exposure period first.

When the camera is set to operate in an externally triggered timing mode the exposure and frame period settings may not apply. (See Section 5.13 for a description of supported triggered timing modes.)

5.12.1. Set Exposure Period

Description	Sets EXPPERIOD, which controls the exposure time (see equation).
Setting Type	Operational
Command	EXP <i>value</i>
Parameters	<i>value</i>
Return Values	none
Range	1 to 16777214
Type	unsigned integer

Example EXP 364651

5.12.2. Get Exposure Period

Description	Returns EXPPERIOD, which controls the exposure time (see equation).
Setting Type	Operational
Command	EXP?
Parameters	none
Return Values	value
Range	1 to 16777214
Type	unsigned integer
Example	EXP ? -- query command 364651 -- return value

5.12.3. Set Frame Period

Description	Sets FRAMEPERIOD, which controls the frame period (see equation).
Setting Type	Operational
Command	FRAME:PERIOD <i>value</i>
Parameters	<i>value</i>
Return Values	none
Range	1 to 16777214
Type	unsigned integer
Example	FRAME:PERIOD 366610

5.12.4. Get Frame Period

Description	Gets FRAMEPERIOD, which controls the frame period (see equation).
Setting Type	Operational
Command	FRAME:PERIOD?
Parameters	none
Return Values	value
Range	1 to 16777214
Type	unsigned integer
Example	FRAME:PERIOD? -- query command

366610 -- return value

5.13. Trigger Commands

The user can change the trigger mode via the serial communication ASCII command TRIG:MODE, which will allow control of the camera timing via 3.3V CMOS Logic signals.

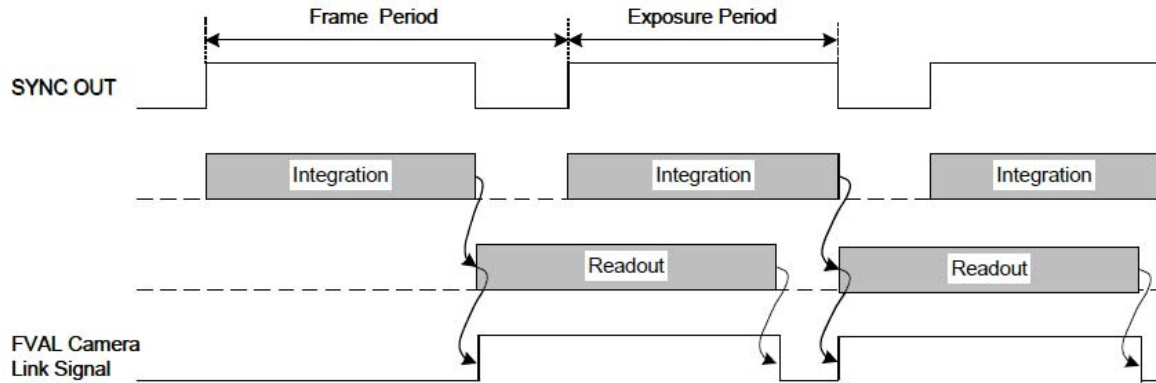

Figure 14 Trigger Mode 0 Freerun timing sequence

When trigger mode 0 is selected, the camera is free-running with the exposure and frame rate internally timed. See Section 5.12 for description of commands to control the internally timed exposure and frame period parameters. When in trigger mode 0, the timing sequence of the camera is as shown in the Figure.

In trigger mode 1, an external trigger timing signal is used to control the exposure and readout timing. An external trigger timing signal can be applied to the camera through the Camera Link CC1 signal. The signal source can be selected via the serial communication ASCII command TRIG:SOURCE. The polarity of the trigger sources can be selected via the serial communication ASCII command TRIG:POL. A latency time delay of 5 - 6 clocks is possible due to the shape and impedance of the incoming trigger, and not added into the following discussion.

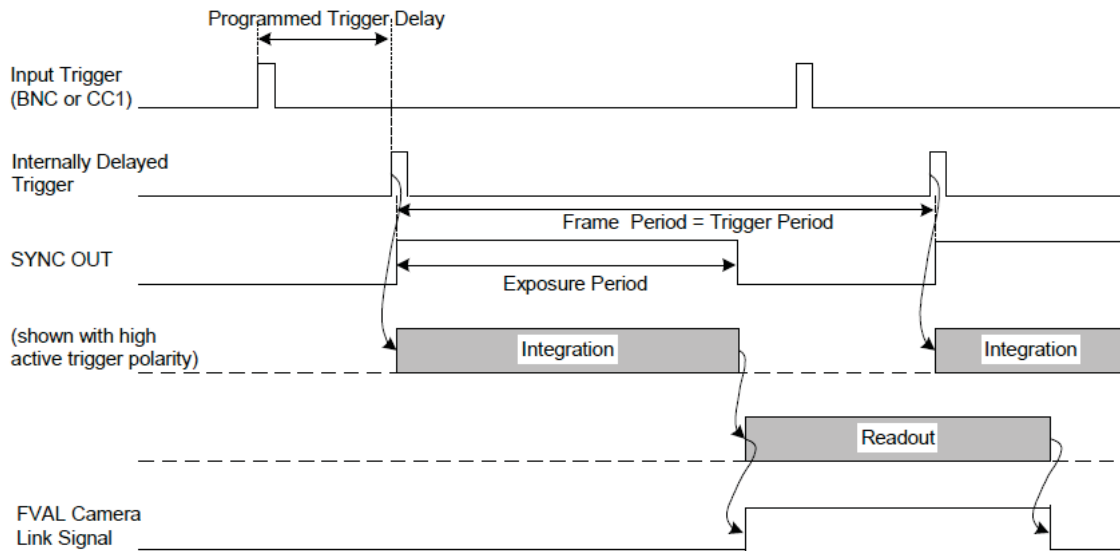

Figure 15 Trigger mode 1 exposure and readout timing sequence.

In trigger mode 1, the camera uses the external trigger signal to control the frame period while internally controlling the exposure period. The minimum trigger pulse width for trigger mode 1 is 0.5µs. The exposure time is set by the operational setting chosen and can be overridden with the EXP command. The camera detects a trigger transition via the currently selected trigger input to initiate exposure (integration). If an active high polarity is selected the camera uses a low to high transition. If active low polarity is selected the camera uses a high to low transition. The delay between this trigger transition and start of exposure is 5 to 6 pixel periods. (See Section 5.12 for a discussion on determining the pixel clock period.) The ceiling of the trigger rate for this mode is the maximum frame rate. If the maximum trigger rate is exceeded, a camera error will be reported as described in Section 5.17.16, yet will not disable the camera’s ability to acquire on future triggers (an error could mean that the camera is missing triggers). Note that some frame grabbers have a time-out that can be exceeded while the camera awaits a trigger; the camera does not time-out. The timing sequence of the camera for trigger mode 1 is shown in the Figure.

In trigger mode 2, the camera uses the external trigger to both externally set the exposure time and the frame rate. During this external triggered mode, the camera waits for a trigger pulse before initiating a scan of the focal plane array. The camera detects a trigger transition via the currently selected trigger input to initiate the start of exposure (integration). It uses the low to high transition, if an active high polarity is selected, or the high to low transition, if an active low polarity is selected. A trigger transition of the opposite polarity ends the exposure. In other words, the active trigger pulse width determines the exposure time and the trigger frequency determines the frame rate. In trigger mode 2, the delay between the trigger transition and start of exposure is 3 to 4 pixel clock periods. The delay between the trigger transition and end of exposure is 3 to 4 pixel clock periods plus 28 pixel clock periods for FPA clocking overhead, as described in Section 5.12. The timing sequence of the camera for trigger mode 2 is shown in

the Figure.

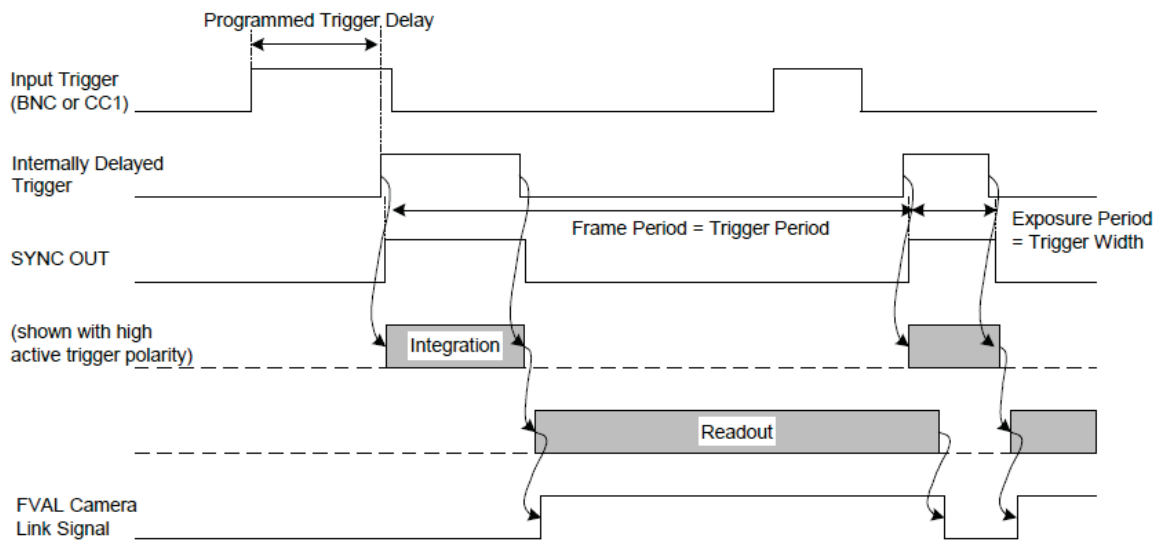

Figure 16 Timing sequence for trigger mode 2

The minimum active trigger pulse width in trigger mode 2 is 8.8 μs . However, 30 μs is the absolute minimum recommended integration time, and 200 μs is the suggested minimum integration time. There is no maximum allowable trigger pulse width, but the user should be aware that as the exposure gets longer, more dark current is integrated by the focal plane array. If the exposure is too long, the focal plane array may saturate with dark current. The ceiling of the trigger rate for this mode is the maximum frame rate. If the maximum trigger rate is exceeded, a camera error will be reported as described in the error Section 5.17.16.

In trigger mode 3, the external trigger signal gates on and off the internal timing of the exposure and line rate. That is, whenever the selected trigger input is in an inactive state the camera is paused. Whenever the selected trigger input is active the camera will operate as though it were free-running. Once an exposure has been initiated, the camera will finish that particular exposure and readout even though the trigger might have already transitioned to an inactive state. Therefore, when the trigger transitions to an inactive state it should be held inactive for a minimum of the exposure period plus the frame readout time. The delay between this trigger transition and start of exposure is 5 to 6 pixel periods. The timing sequence of the camera for trigger mode 3 is shown in the Figure.

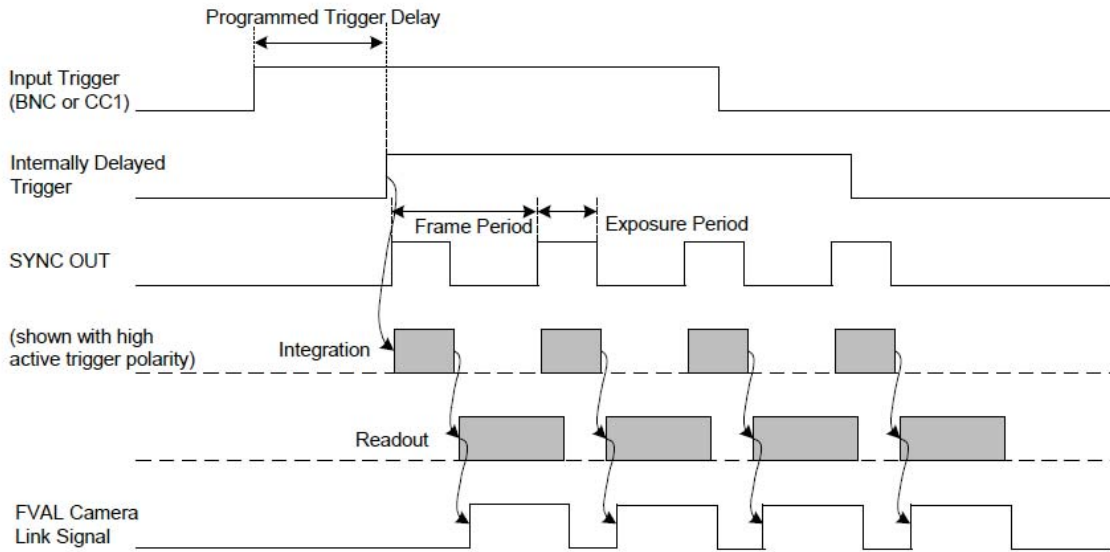

Figure 17 Timing sequence for trigger mode 3

5.13.1. Set Trigger Mode

Description	Sets the trigger and timing modes. Note: Execution of this command that results in a change in trigger mode will also apply a reset to the trigger and FPA scan digital logic clearing any existing trigger or scan errors.
Setting Type	Global
Command	TRIG:MODE <i>mode</i>
Parameters	<i>mode</i>
Return Values	none
Range	0 Internally triggered, internally timed 1 Externally triggered, internally timed 2 Externally triggered, externally timed 3 Externally gated, internally timed
Type	unsigned integer
Example	TRIG:MODE 1

5.13.2. Get Trigger Mode

Description	Returns the trigger and timing mode.
Setting Type	Global
Command	TRIG:MODE?

Parameters	none
Return Values	mode
Range	0 Internally triggered, internally timed 1 Externally triggered, internally timed 2 Externally triggered, externally timed 3 Externally gated, internally timed
Type	unsigned integer
Example	TRIG:MODE? -- query command 1 -- return value

5.13.3. Set Trigger Source Mode

Description	Sets the trigger source mode. The camera can accept triggers from the Camera Link CC1 signal as well as the Trigger port in the AUX/POWER connector. Note: Execution of this command that results in a change in trigger source will also apply a reset to the trigger and FPA scan digital logic clearing any existing trigger or scan errors.
Setting Type	Global
Command	TRIG:SOURCE <i>value</i>
Parameters	<i>value</i>
Return Values	none
Range	0 – 3 0 None 1 Camera Trigger Port 2 Camera Link CC1 3 Either Camera Trigger Port ‘OR’ CC1 (‘AND’ function not enabled)
Type	unsigned integer
Example	TRIG:SOURCE 2

5.13.4. Get Trigger Source Mode

Description	Returns the trigger source mode.
Setting Type	Global
Command	TRIG:SOURCE?
Parameters	none

Return Values	value
Range	0 - 3
	0 None
	1 Camera Trigger Port
	2 Camera Link CC1
	3 Either Camera Trigger Port ‘OR’ CC1 (‘AND’ function not enabled)
Type	unsigned integer
Example	TRIG:SOURCE? -- query command 2 -- return value

5.13.5. Set Trigger Polarity

Description	Sets the trigger polarity. Active high indicates that a low to high transition will trigger the camera and the high pulse width of the trigger signal will set the exposure period when in externally timed mode. Note: Execution of this command that results in a change in trigger polarity will also apply a reset to the trigger and FPA scan digital logic clearing any existing trigger or scan errors.			
Setting Type	Global			
Command	TRIG:POL <i>value</i>			
Parameters	<i>value</i>			
Return Values				
Range	Trigger	Camera Link	CC1	
	0	High	High	active
	1	Low	High	active
	2	High	Low	active
	3	Low	Low	active
Type	unsigned integer			
Example	TRIG:POL 0			

5.13.6. Get Trigger Polarity

Description	Returns the trigger polarity.
Setting Type	Global
Command	TRIG:POL?

Parameters	none
Return Values	value
Range	Trigger Camera Link CC1
	0 High High active
	1 Low High active
	2 High Low active
	3 Low Low active
Type	unsigned integer
Example	TRIG:POL? -- query command 0 -- return value

5.13.7. Set Trigger Delay

Description	Sets the number of pixel clock cycles to delay the external trigger source signal. This delay is in addition to the minimum delays. The selected delay must be less than the trigger source period for proper delay operation.
Setting Type	Global
Command	TRIG:DELAY <i>value</i>
Parameters	<i>value</i>
Return Values	none
Range	0 to 16777215 (0 to $(2^{24} - 1)$ clocks)
Type	unsigned integer
Example	TRIG:DELAY 1000

5.13.8. Get Trigger Delay

Description	Returns the trigger delay setting.
Setting Type	Global
Command	TRIG:DELAY?
Parameters	none
Return Values	value
Range	0 to 16777215
Type	unsigned integer
Example	TRIG:DELAY? -- query command 1000 -- return value

5.14. Gain Commands

5.14.1. Set Digital Gain

Description	<p>Sets the digital gain value applied when AGC is off (AGC:ENABLE OFF). Digital gain can be used to ensure that the image data fills the digital output range when offset and gain corrections are applied. In addition, digital gain can be used to stretch low signal images across a greater portion of the output range. Digital gain does not inherently improve signal to noise ratio, except by causing uniform saturation.</p> <p>This command accepts multiple formats:</p> <p>Integer input: 1 - 511 (no decimal)</p> <p>Floating Point: 0.03125 to 16.0 (decimal used) in 1/32 steps 32 = 1.0</p>
Setting Type	Global
Command	GAIN:DIGITAL <i>value</i>
Parameters	<i>value</i>
Return Values	none
Range	1 to 511; 0.03125 to 16.0
Type	decimal OR integer
Example	<p>one of</p> <p>GAIN:DIGITAL 64</p> <p>GAIN:DIGITAL 2.0</p>

5.14.2. Get Digital Gain

Description	Returns the digital gain value in the format it was set.
Setting Type	Global
Command	GAIN:DIGITAL?
Parameters	none
Return Values	value
Range	1 to 511; 0.03125 to 16.0
Type	decimal or unsigned integer
Example	<p>GAIN:DIGITAL? -- query command (corresponding one of)</p> <p>64 -- return value</p> <p>2.0 -- return value</p>

5.15. Thermal Commands

When the camera is powered on, the thermoelectric cooler (TEC) will immediately begin driving the FPA to the TEC setpoint. Until the FPA reaches and stabilizes on the setpoint, the TEC is “unlocked” and the LED will show red. Once the TEC drives the FPA temperature to the TEC setpoint, the TEC is considered “locked” and the LED will show green. The LED may oscillate between showing red and green for a few seconds before stable TEC lock is achieved and the LED shows solid green.

A solid red LED indicates that the camera is unable to reach or maintain TEC lock. This may be caused if the case temperature falls outside of the acceptable range for a given TEC setpoint. These acceptable ranges are described in Section 1.5 Thermal Management. If the case temperature is within the acceptable range for the given TEC setpoint, try cycling power to the camera. If the LED continues to show solid red, contact the factory for support.

5.15.1. Get System Temperature

Description	Returns an approximation of the camera system temperature in degrees Celsius. Optional: add Kelvin to the end of the command for results in Kelvin. Note: SYSTEM:TEMP? is an approximation based upon a temperature sensor on the digital board.
Setting Type	Operational
Command	SYSTEM:TEMP? <i>Kelvin</i>
Parameters	none or <i>Kelvin</i>
Return Values	temperature value
Range	-50.00 to +70.00 or 223.00 to 373.00 (K)
Type	signed decimal
Example	SYSTEM:TEMP? -- query command 37.81 -- return value 310.95 Kelvin -- return value

5.15.2. Get FPA Temperature

Description	Returns an approximation of the camera Focal Plane Array (FPA) temperature in degrees Celsius. Optional: add Kelvin to the end of the command for results in Kelvin. Note: FPA:TEMP? is an approximation based upon a temperature sensor near the array.
Setting Type	N/A
Command	FPA:TEMP? -or- FPA:TEMP? Kelvin
Parameters	none or <i>Kelvin</i>
Return Values	temperature
Range	-50.00 to +70.00, 223.00 to 343.00 (K)
Type	signed decimal

Example	FPA:TEMP? -- query command (one of) 37.81 -- return value 310.95 Kelvin -- return value
---------	--

5.15.3. Get Thermoelectric Cooler Lock Status

Description	Returns status of the thermoelectric cooler stabilization lock of the focal plane array temperature to the setpoint. The temperature is considered locked when the current temperature is within $\pm 0.1^{\circ}\text{C}$ of the setpoint. The TEC should remain locked when the case temperature is maintained within a given range, see Section 1.5.
Setting Type	N/A
Command	TEC:LOCK?
Parameters	none
Return Values	status
Range	LOCKED TEC stabilized NOT LOCKED TEC not stabilized
Type	string
Example	TEC:LOCK? -- query command LOCKED -- return value

5.15.4. Get Thermoelectric Cooler Setpoint

Description	Returns the thermoelectric cooler temperature setpoint in degrees Celsius.
Setting Type	Operational
Command	TEC:SETPOINT?
Parameters	none
Return Values	value
Range	-20 to 80
Type	integer
Example	TEC:SETPOINT? -- query command 22 -- return value

5.15.5. Set Thermoelectric Cooler State

Description	Sets the state of the thermoelectric cooler.
-------------	--

Setting Type	Global
Command	TEC:ENABLE <i>state</i>
Parameters	<i>state</i>
Return Values	none
Range	ON Enables TEC OFF Disables TEC
Type	string
Example	TEC:ENABLE ON

5.15.6. Get Thermoelectric Cooler State

Description	Returns the state of the thermoelectric cooler.
Setting Type	Global
Command	TEC:ENABLE?
Parameters	<i>state</i>
Return Values	none
Range	ON TEC Enabled OFF TEC Disabled
Type	string
Example	TEC:ENABLE? -- query command ON -- return value

5.15.7. Wait for TEC Lock

Description	Blocks operation of camera until TEC is locked. Useful in cases where passed data needs to be properly stabilized, such as in performing an updated background correction file. Camera operation is prevented for up to 60 seconds, and will unblock when a stable TEC lock signal is achieved. Queries while blocked are not received.
Setting Type	Global
Command	TEC:WAIT
Parameters	none
Return Values	none
Range	none

Type	n/a
Example	TEC:WAIT – command (video is still output, no commands can be sent until WAIT is released) -- return value

5.16. Digital Output Commands

5.16.1. Set Digital Data Source

Description	The digital data source can be set to one of several stages along the digital signal path. See signal flow path diagram in Section 4.2.
Setting Type	Global
Command	DIGITAL:SOURCE <i>source</i>
Parameters	<i>source</i>
Return Values	none
Range	RAW Stage 1, Raw Data 12 bits PAT Stage 2, Test Pattern 12 bit CORR Stage 3, Corrected Data 12 bits BPR Stage 4, Pixel Replace BIN Stage 5, Binned Data 12 bits ENH Stage 6, Enhancement Data FSTAMP Stage 7, Frame Stamp
Type	string
Example	DIGITAL:SOURCE ENH

5.16.2. Get Digital Data Source

Description	Returns the source of the digital data.
Setting Type	Global
Command	DIGITAL:SOURCE?
Parameters	none
Return Values	source
Range	RAW Stage 1, Raw Data 12 bits PAT Stage 2, Test Pattern 12 bit CORR Stage 3, Corrected Data 12 bits BPR Stage 4, Pixel Replace

BIN Stage 5, Binned Data 12 bits
 ENH Stage 6, Enhancement Data
 FSTAMP Stage 7, Frame Stamp

Type string
 Example DIGITAL:SOURCE? -- query command
 ENH -- return value

5.17. Camera Information Commands

5.17.1. Get Camera Serial Number

Description Returns the camera serial number.
 Setting Type Global
 Command CAMERA:SN?
 Parameters none
 Return Values value
 Range up to 9 character alpha numeric string
 Type string
 Example CAMERA:SN? -- query command
 1337S9738 -- return value

5.17.2. Get Camera Part Number

Description Returns the camera part number.
 Setting Type Global
 Command CAMERA:PN?
 Parameters none
 Return Values value
 Range up to 9 character alpha numeric string
 Type string
 Example CAMERA:PN? -- query command
 8000-0773 -- return value

5.17.3. Get Camera Revision

Description Returns the camera revision.
 Setting Type Global

Command	CAMERA:REV?
Parameters	none
Return Values	value
Range	up to 9 character alpha numeric string
Type	string
Example	CAMERA:REV? -- query command A -- return value

5.17.4. Get Firmware Part Number

Description	Returns the part number of the camera's firmware.
Setting Type	Global
Command	FIRM:PN?
Parameters	none
Return Values	value
Range	up to 9 character alpha numeric string
Type	string
Example	FIRM:PN? -- query command 4102-0156 -- return value

5.17.5. Get Firmware Revision

Description	Returns the revision of the camera's firmware.
Setting Type	Global
Command	FIRM:REV?
Parameters	none
Return Values	value
Range	up to 9 character alpha numeric
Type	string
Example	FIRM:REV? -- query command 2.2 -- return value

5.17.6. Get Hardware Revision

Description	Returns the revision of the camera's hardware.
Setting Type	Global

Command	VER:HW?
Parameters	none
Return Values	value
Range	up to 9 character alpha numeric string
Type	string
Example	VER:HW? -- query command 1187 -- return value

5.17.7. Get Software Revision

Description	Returns the revision of the camera's software.
Setting Type	Global
Command	VER:SW?
Parameters	none
Return Values	value
Range	up to 9 character alpha numeric string
Type	string
Example	VER:SW? -- query command P2.2 -- return value

5.17.8. Get Focal Plane Array Serial Number

Description	Returns the serial number of the camera's focal plane array.
Setting Type	Global
Command	FPA:SN?
Parameters	none
Return Values	value
Range	up to 9 character alpha numeric string
Type	string
Example	FPA:SN? -- query command 3713S5870 -- return value

5.17.9. Get Focal Plane Array Number of Columns

Description	Returns the number of columns of the focal plane array.
Setting Type	Global
Command	FPA:COLS?

Parameters	none
Return Values	value
Range	0 to 65535
Type	unsigned integer
Example	FPA:COLS? -- query command 640 -- return value

5.17.10. Get Focal Plane Array Number of Rows

Description	Returns the number of rows of the focal plane array.
Setting Type	Global
Command	FPA:ROWS?
Parameters	none
Return Values	value
Range	0 to 65535
Type	unsigned integer
Example	FPA:ROWS? -- query command 512 -- return value

5.17.11. Get Elapsed Time Meter

Description	Returns the total amount of time the camera has been powered on since production. User is unable to reset.
Setting Type	Global
Command	ETM?
Parameters	none
Return Values	value (Days Hours:Minutes:Seconds)
Range	0 - 2^{32} seconds, or about 136 yrs
Type	String
Example	ETM? -- query command Days:8 04:03:02 -- return value

5.17.12. Set Application Timer

Description	Sets the status of a timer which is stored in volatile memory. Resolution is 0.1 second. Register is lost if power is interrupted.
Setting Type	Global

Command	AP:TIMER <i>mode</i>
Parameters	<i>mode</i>
Return Values	none
Range	ON Reset timer to 0 and start timer OFF Stop timer
Type	string
Example	AP:TIMER ON

5.17.13. Get Application Timer

Description	Gets the status of a timer which is stored in volatile memory.
Setting Type	Global
Command	AP:TIMER?
Parameters	none
Return Values	value (Seconds)
Range	N/A
Type	String
Example	AP:TIMER? -- query command 105.4 -- return value in seconds

5.17.14. Get Camera Command List

Description	Returns the camera command list. The list includes commands in this manual, as well as optional commands beyond the manual's scope, support or validation. An optional prefix can be used to reduce the output list size.
Setting Type	N/A
Command	CMDS? [<i>prefix</i>]
Parameters	<i>prefix (optional)</i>
Return Values	value (command)
Range	N/A
Type	string
Example	CMDS? BA -- query command BAUD:CURRENT -- response value (beginning with 'BA' in this example) BAUD:CURRENT? -- cont. BAUD:FUTURE -- cont. BAUD:FUTURE? -- cont.

CMDS? AGC -- query command
 (prefix match, all AGC commands will be output)
 CMDS? 4
 (outputs in 4 columns)
 CMDS? HELP
 (display complete help contents for all commands)
 CMDS AGC H
 display all AGC commands and Help 1 command per line

5.17.15. Get Camera Command Description

Description	Returns a brief description for a user entered command. Suggested: the CMDS? function lists the proper command format (CMDS? A shortens the list by commands only starting with 'A' etc.) and then you can use the camera formatted command in the Help.
Setting Type	N/A
Command	HELP? <i>command</i>
Parameters	<i>[exact command]</i>
Return Values	value (description)
Range	N/A
Type	string
Example	HELP? OPR -- query command Sets the camera OPR -- response: text description of the query

5.17.16. Status and Reset Commands

The user can poll the camera's error status with the error command, which returns a binary encoded 32-bit error value. A non-zero error code indicates that an error has occurred. Table 8 below can be used to decode the error value returned by the error command. A bit value of one indicates an error. Use the "ON" argument.

Bit	Error Description	Cause	Resolution
0 (LSB)	PLL0 error	Internal error	Power cycle camera
1	PLL1 error	Internal error	Power cycle camera
2	PLL2 error	Internal error	Power cycle camera

3	Expose Block Error	Invalid exposure and / or frame rate timing	<ol style="list-style-type: none"> 1. Increase readout time by modifying exposure and frame periods. 2. Reduce trigger rate. 3. Reset firmware, reboot camera, or send a trigger command that causes a trigger parameter change (see section Error! Reference source not found.).
4	Data RX PLL Lock Error	Internal error	Power cycle camera
5..15	Unused	Unused	Unused
16	I2C0 Error	Internal Error	Power cycle camera
17	I2C1 Error	Internal Error	Power cycle camera
18	I2C2 Error	Internal Error	Power cycle camera
19	I2C3 Error	Internal Error	Power cycle camera
20	System Temperature Alarm	Camera Temperature is out of acceptable range	<ol style="list-style-type: none"> 1. Reduce camera case temperature 2. Disable TEC. 3. Turn off camera and let cool.
21	FPA Temperature Alarm	FPA Temperature is out of acceptable range.	<ol style="list-style-type: none"> 1. Disable TEC. 2. Power off camera and let cool.
22	Camera Alignment Error	Internal Error	Power Cycle Camera
23	Corr DL Suspend	Correction Download in Progress	No action required
24	AGC High/Low OPR Error	AGC High and Low OPR settings are invalid.	Correct OPR High/Low OPR settings.

25..31 (MSB)	Unused	Unused	Unused
-----------------	--------	--------	--------

Table 8. Error value descriptions, causes and resolutions.

For text descriptions of the error bit fields use the command options ON and ALL.

Command	Response
ERROR?	Returns the 32-bit error register value only
ERROR? ON	Returns the error register value and its text description
ERROR? ALL	Returns the list of all error register values and their text descriptions

5.17.17.Reboot Camera

Description	Execute the power-up initialization sequence of the command processor. This will also clear the power-down detect flag.
Setting Type	N/A
Command	REBOOT
Parameters	none
Return Values	start-up banner
Range	N/A
Type	string
Example	REBOOT -- restart command processor

5.17.18.Set Power-Down Detect Flag

Description	Sets the power-down detect flag to 1. On reboot, this flag is initialized to 0. As the value is set using this command, the user can query its status to detect if the camera has been power cycled since the last query. The command sets the flag; only a reboot will reset the flag to 0.
Setting Type	N/A
Command	PWRDWN
Parameters	none
Return Values	none
Range	N/A
Type	N/A
Example	PWRDWN -- set power-down detect flag

5.17.19. Get Power-Down Detect Flag

Description	Returns the power-down detect flag status.
Setting Type	N/A
Command	PWRDWN?
Parameters	none
Return Values	value
Range	0 Initial value on reboot 1 Value set by user to monitor power-down status
Type	unsigned integer
Example	PWRDWN? -- query command 1 -- camera not power cycled

5.17.20. Set LED State

Description	Sets the state of the status LED. Note: At least one SUI camera used the command LED instead of as shown. If you have legacy software code and are experiencing difficulty, check the command being used.
Setting Type	Global
Command	LED:ENABLE
Parameters	<i>state</i>
Return Values	none
Range	ON Enables LED OFF Disables LED
Type	string
Example	LED:ENABLE ON

5.17.21. Get LED State

Description	Returns the state of the status LED.
Setting Type	Global
Command	LED:ENABLE?
Parameters	<i>state</i>
Return Values	value

Range	ON Enables LED OFF Disables LED
Type	string
Example	LED:ENABLE? -- query command ON -- return value

5.18. **Binning Mode Commands**

Binning Mode shifts SU320CSX camera imaging from a 320x256 to a 160x128 pixel mode of operation. Enabling Binning Mode produces a like sized image with each 2x2 bin equal to the average of the 4 individual pixels. To maintain compatibility with video and Camera Link signals, binned pixel results consist of the binned block's pixels being set to the same value (value is repeated), and the full frame image is still sent.

Binning in a PDA is unlike binning on a CCD: The charge is read individually and summed in camera firmware. Noise improvement comes from the summing and averaging of the pixels: a 2x2 pixel bin has $\text{root}(4) = 2x$ noise improvement.

To maintain data transportation consistency, the image size does not change: the block of binned pixels are given the same digital value.

5.18.1. **Set Binning Mode State**

Description	Sets the state of Binning Mode. Pixels are binned on a 2x2 pattern only.
Setting Type	Global
Command	BIN:ENABLE <i>state</i>
Parameters	<i>state</i>
Return Values	value
Range	ON Enables Binning Mode OFF Disables Binning Mode
Type	string
Example	BIN:ENABLE ON

5.18.2. **Get Binning Mode State**

Description	Gets the state of Binning Mode.
Setting Type	Global
Command	BIN:ENABLE?

Parameters	none
Return Values	value
Range	ON Binning Mode Enabled OFF Binning Mode Disabled
Type	string
Example	BIN:ENABLE? -- query command ON -- return value

5.19. Test Commands

The Test Pattern mode can be used to verify the integrity of the data collection. When this mode is enabled, the camera returns one of four image patterns with predictable values. The timing of the data presenting on the Camera Link interface remains unchanged from when active pixel data is returned. The test pattern data is returned for all pixels. The Test Pattern conforms to the current Window size. See Section 5.21 Windowing Commands. The test pattern data is only transmitted over the interface as described if the Digital Signal Source is set to PAT. (See Digital Source command.)

5.19.1. Set Test Pattern State

Description	Sets the test pattern state. When ON, a test pattern is returned in place of data from the focal plane array. One of four patterns may be selected.	
Setting Type	Global	
Command	TESTPAT <i>state</i>	
Parameters	<i>state</i>	
Return Values		
Range	ON TP0	Enable test pattern TP0
	ON TP1	Enable test pattern TP1
	ON TP2	Enable test pattern TP2
	ON TP3	Enable test pattern TP3
	OFF	Disable test pattern
Type	string	
Example	TESTPAT ON TP0 TESTPAT ON (Defaults to TP0) TESTPAT TP2 (ON is default) TESTPAT OFF	

5.19.2. Get Test Pattern State

Description	Returns the state of the test pattern.
Setting Type	Global
Command	TESTPAT?
Parameters	none
Return Values	state
Range	ON Test pattern enabled OFF Test pattern disabled
Type	string
Example	TESTPAT? -- query command ON TP3 -- return value

5.19.3. Set Frame Stamp

Description	Sets the frame stamp state. When ON, a count value incrementing by 1 of extents 0 to 4095 is returned in place of the first pixel in the frame.
Setting Type	Global
Command	FRAME:STAMP <i>state</i>
Parameters	<i>state</i>
Return Values	none
Range	ON Enable frame stamp OFF Disable frame stamp
Type	string
Example	FRAME:STAMP ON

5.19.4. Get Frame Stamp State

Description	Returns the Frame Stamp state.
Setting Type	Global
Command	FRAME:STAMP?
Parameters	none
Return Values	state
Range	ON Frame stamp enabled

OFF Frame stamp disabled

Type string
 Example FRAME:STAMP? -- query command
 ON -- return value

5.19.5. Get Frame Stamp Count

Description Returns the Frame Stamp count.
 Setting Type Global
 Command FRAME:STAMP:COUNT?
 Parameters none
 Return Values value
 Range 0 - 4095

Type string
 Example FRAME:STAMP:COUNT? -- query command
 2017-- return value

5.20. Macro Commands

The camera supports the ability to execute multiple commands with the issuance of a single macro command. Factory stored macros are used to adjust the TEC setpoint and corresponding operational settings. These are documented in the separate Appendix B document. The user is not able to specify custom macros.

5.20.1. Play Macro Command

Description Plays a macro that is resident in the camera. Turning *macro_echo* on will cause the individual commands being executed to be displayed.
 Setting Type Global
 Command MACRO:PLAY *macro_echo macro_number*
 Parameters *macro_echo, macro_number*
 Return Values Final OK or ERROR with *macro_echo* off , return values of any query commands contained in the macro with *macro_echo* ON and Final OK or ERROR
 Range *macro_echo* ON OFF
macro_number 0 – 9
 Type string (*macro_echo*), unsigned integer (*macro_number*)

Example

MACRO:PLAY OFF 0

5.21. Windowing Commands

The CSX camera allows for windowing of an image to a user's region of interest (ROI). Windowing is typically used to trade image resolution for frame rate. The smaller the window chosen, the shorter the readout time for the frame and, hence, the higher the frame rate that can be achieved. The display enhancements should be turned off (ENH:ENABLE OFF, see Section 5.10.1) and the AGC should be turned off (AGC:ENABLE OFF, see Section 5.9.1) when windowing. This is recommended because enhancements and AGC use the full frame statistics, not the window statistics.

Note that a 320x256 array includes commands to point 0,0 and thus the maximum 'logical' extent is 319, 255. When inputting specific pixel locations to the camera firmware, the logic notation applies and the array maximum is 319x255. The concept of 'odd' and 'even' is defined on the logic value of the pixel notation, so the origin 0 of (0,0) is an even number, and 319 of (319,255) is an odd number, regardless that these refer to the 1st pixel and 320th pixel.

The WIN:ROW and WIN:COL commands can be used to define each corner of the window individually. Alternatively, the WIN:RECT command can be used to define the window with a single command.

Windowing speed advantage applies to rows only (i.e. the number of columns is fixed at 320 [319]). Selecting the start and stop row addresses sets the size and location for the ROI window. There are two individual commands that set start and stop addresses for rows. The start row address must be an EVEN number while the stop row address must be an ODD number. Additionally, the resulting height of the window must be greater than 2; because of the start or stop needing to be an EVEN or ODD number, a minimum size is thus 4. The WIN commands must specify start addresses lower or equal to corresponding stop addresses and must be within the allowed range for the supported FPA for these commands to complete without error.

A smaller column number may be set, even as there is no speed improvement. This will allow the user to save smaller images and video sets.

5.21.1. Set Window Column Start Number

Description	Sets the start column number for the ROI. The value must be an EVEN number and compatible with the current column stop number for the command to complete without error.
Setting Type	Operational
Command	WIN:COL:START <i>value</i>
Parameters	<i>value</i>
Return Values	none
Range	0 to 316
Type	unsigned integer
Example	WIN:COL:START 10 -- start read at col 10

5.21.2. Get Window Column Start Number

Description	Returns the start column number for the ROI.	
Setting Type	Operational	
Command	WIN:COL:START?	
Parameters	none	
Return Values	value	
Range	0 to 316	
Type	unsigned integer	
Example	WIN:COL:START?	-- query command
	120	-- return value

5.21.3. Set Window Column Stop Number

Description	Sets the stop column number for the ROI. The value must be ODD and compatible with the current column start number for the command to complete without error.	
Setting Type	Operational	
Command	WIN:COL:STOP <i>value</i>	
Parameters	<i>value</i>	
Return Values	none	
Range	3 to 319	
Type	unsigned integer	
Example	WIN:COL:STOP 229 -- stop read at 229 (must accommodate location of start)	

5.21.4. Get Window Column Stop Number

Description	Returns the stop column number for the ROI.	
Setting Type	Operational	
Command	WIN:COL:STOP?	
Parameters	none	
Return Values	value	
Range	3 to 316	
Type	unsigned integer	
Example	WIN:COL:STOP?	-- query command
	229	-- return value

5.21.5. Set Window Row Start Number

Description	Sets the start row number for the ROI. The value must be EVEN and compatible with the current row stop number for the command to complete without error.
Setting Type	Operational
Command	WIN:ROW:START <i>value</i>
Parameters	<i>value</i>
Return Values	none
Range	0 to 248
Type	unsigned integer
Example	WIN:ROW:START 64 -- start read at row 64

5.21.6. Get Window Row Start Number

Description	Returns the start row number for the ROI.
Setting Type	Operational
Command	WIN:ROW:START?
Parameters	none
Return Values	value
Range	0 to 248
Type	unsigned integer
Example	WIN:ROW:START? -- query command 16 -- return value

5.21.7. Set Window Row Stop Number

Description	Sets the stop row number for the ROI. The value must be ODD and compatible with the current row start number for the command to complete without error.
Setting Type	Operational
Command	WIN:ROW:STOP <i>value</i>
Parameters	<i>value</i>
Return Values	none
Range	7 to 255
Type	unsigned integer
Example	WIN:ROW:STOP 191 -- stop read at row 191

5.21.8. Get Window Row Stop Number

Description	Returns the stop row number for the ROI.	
Setting Type	Operational	
Command	WIN:ROW:STOP?	
Parameters	none	
Return Values	value	
Range	7 to 255	
Type	unsigned integer	
Example	WIN:ROW:STOP? 191 -- return value	-- query command

5.21.9. Set Window Rectangle

Description	Sets the global corner row and column numbers for the ROI. The Total rows and columns must be an even value for each: Start on an EVEN number and end on an ODD number, and conform to minimum size requirements.	
Setting Type	Global	
Command	WIN:RECT <X1> <X2> <Y1> <Y2>	
Parameters	<X left> <X right> <Y top> <Y bottom>	
Return Values	None	
Range	0 to 319 for SU640HSX for corner row value 0 to 255 for SU640HSX for corner column value	
Type	unsigned integers	
Example	WIN:RECT 16 8 217 111 -- set window row and column points	

5.21.10. Get Window Rectangle

Description	Gets the global corner row and column numbers for the ROI.	
Setting Type	Global	
Command	WIN:RECT?	
Parameters	none	
Return Values		
Range	0 to 319 for SU640HSX for corner row value 0 to 255 for SU640HSX for corner column value	

Type unsigned integers
Example WIN:RECT?
X1:0 Y1:0 X2:217 Y2:111 -- return values

6. Specifications

6.1. Mechanical Specifications

Width x Height x Length	ENC Series: 1.25"W x 1.25"H x 1.20"D (31.8 x 31.8 x 30.6 mm) OEM Series: 1.25"W x 1.20"H x 1.19"D (31.8 x 30.6 x 30.2 mm)
Weight	≤45 grams enclosed, ≤41 grams OEM
Focal Plane Array Format	320 x 256 pixels
Pixel Pitch	12.5 μm
Active Area	4.0 mm x 3.2 mm (5.1 diagonal)

6.2. Environmental and Power Specifications

Operating Case Temperature	-5C to 60°C
Storage Temperature	-54°C to 85°C
Humidity	95% RH non-condensing
Power Requirements:	
AC Adapter Supplied	100-240 VAC, 47-63 Hz
DC Voltage	+4.5 - 16 V
Typical Power	1.5 W at 20°C (excluding transients)
Maximum Power	<4.25 W
I/O Logic levels	3.3 V CMOS Logic compliant
Functional Shock, Thermal Shock, Random Vibration	MIL-STD-810G compliant design
Conducted & Radiated Emissions	FCC CFR 47, Part 15, Conducted Emission FCC CFR 47, Part 15, Radiated Emission MIL-STD-461F, CE102 MIL-STD-461F, RE102
Mean Time Between Failure	≥ 10,000 hours per MIL-HDBK-217F with VITA51.1 supplement
Fungus-Inert Material	Yes

6.3. Electro-Optic Performance Specifications

Optical Fill Factor	100%	
Spectral Response	900 nm to 1700 nm (SWIR) 700 nm to 1700 nm (NIR)	
Quantum Efficiency	≥65% from 1000 nm to 1600 nm	
Digital Output Frame Rate	30 fps	60 fps
Mean Detectivity, $D^* \text{ }^1 (cm \cdot \sqrt{Hz}/W)$	≥ 2.5 x10 ¹³	≥ 2.8 x10 ¹³
Noise Equivalent Irradiance ¹ (photons/cm ² /s)	≤ 9.7 x10 ⁸	≤ 1.2 x10 ⁹
Noise (RMS) ¹	≤ 35 electrons	≤ 25 electrons
Dynamic Range High Gain ¹	≥ 800:1	≥ 1100:1
Dynamic Range Low Gain ¹	≥ 1700:1	≥ 2500:1
Operability ²	≥ 99%	
Image Correction	Sensors Unlimited non-uniformity corrections	
Scan Mode	Continuous	

¹ typical, $\lambda = 1550$ nm, exposure time = 33 ms (30FPS) / 16.67 ms (60FPS), case temperature = 20°C, highest sensitivity gain setting, no lens, corrections off, 1x digital gain, with AGC, enhancement, and correction off.

² The percentage of pixels with responsivity deviation less than 35% from the mean.

7. Product Support

Common Problems and Solutions

Problem	Possible Causes	Solution
No data is present at the digital port, frame grabber times out	Power is off or low	Verify input power meets requirements described.
	Connections to camera are fully or partially disconnected.	Verify cameras wiring is properly connected.
	Camera is in external trigger mode, but not receiving a trigger.	Test the camera in internal trigger mode (TRIG:MODE 0) to confirm normal operation. If internal trigger mode operation is normal, see “Camera is not responding to trigger input.”
Camera will not respond to trigger inputs	Trigger source is not connected.	Verify trigger is properly connected. Verify frame grabber trigger source is properly configured if using Camera Link CC1.
	Trigger signal does not conform to timing requirements of the camera.	Verify trigger source meets the timing requirements described in Section 5.13. Check camera error status for a trigger or scan error. If oscilloscope is available, view the trigger input signal to verify it meets the requirements of the camera for the selected trigger mode.
	Trigger logic levels are incorrect.	Verify camera logic levels match logic being sent.
Camera intermittently responds to triggers, resulting in missing frames, or in some cases timeout errors	Trigger period is too short, causing following triggers to be ignored as they occur during readout.	Check camera error status for a trigger or scan error (>ERROR? ON). Modify trigger to meet timing requirements for the selected trigger mode and supported FPA.
Frame grabber software reports not receiving enough data before timing out	Acquisition size parameters larger than actual data available.	Reduce acquisition window size parameters, decrementing one pixel or line at a time. Some frame grabbers require overhead pre- or post-valid pixels or lines to properly grab the digital data.

8. Customer Support

For additional product support please contact SUI between 8am and 5pm Eastern Time at 609-333-8000 and ask to speak with an applications engineer.

For general information about this product or for information on SUI's line of other image sensing products, please contact:

UTC AEROSPACE SYSTEMS
ISR & Space Systems
330 Carter Road
Suite 100
Princeton, NJ. 08540, USA
Tel: +1 609 333 8000 Fax: +1 609 333-8103
www.sensorsinc.com

9. Warranty

All SUI products are warranted to be free from defects in workmanship and materials “Nonconformity” for a period of 12 months from the date of shipment. This warranty is limited to the repair or replacement of the unit.

This warranty does not apply to products which SUI determines, upon inspection, have failed, become defective or unworkable due to abuse, mishandling, misuse, alteration, negligence, improper installation, use which is not in accordance with the information and precautions described in the applicable operating manual, or other causes beyond SUI’s control.

This warranty does not apply to (i) any products or components not manufactured by SUI or (ii) any aspect of the products based on Buyer’s specification, unless Seller has reviewed and approved such specification in writing.

In-warranty repaired or replacement products are warranted only for the remaining non-expired portion of the original warranty period.

Except for the foregoing warranty, SUI specifically disclaims and excludes all other warranties, expressed or implied, including implied warranties of non-infringement, merchantability or fitness for a particular purpose.

If visible damage has occurred: It must be noted on all copies of the freight bill and signed by the driver. This preserves your rights and the carrier’s liability.

If damage was concealed: Open all cartons as soon as possible! Concealed damage must be reported in writing within 5 days of receipt. Contact our shipping department for assistance between 8:00 A.M. and 5:00 P.M. ET (prevailing).

All product returns require contacting the factory to request a Return Material Authorization number (RMA). End users reporting a problem should be prepared to supply the product model number, serial number, description of the problem, and relevant information about the instrumental setup, environmental conditions, user history, etc., as well as contact information. When returning a camera, all accessories, power supplies, cables and camera case should be included to ensure the user problem can be duplicated and corrected.

10. LIST OF ABBREVIATIONS

ADC: analog-to-digital converter
ASCII: American standard code for information interchange
CCD: Charge Coupled Device (silicon-based sensor <1.1 micron response; not InGaAs technology)
CDS: correlated double sampling
CMOS: complimentary metal-oxide semiconductor
EST: Eastern Standard Time. Normally implies prevailing time to accommodate Daylight Savings Time
FPA: focal plane array
FPS: frames per second
FPGA: field programmable gate array
GMOD: gate modulated in-pixel amplifier
IMAQ: Image Acquisition (National Instruments' frame grabber driver software)
ITAR: International Traffic in Arms Regulations
InGaAs: indium gallium arsenide
ITAR: International Traffic in Arms Regulations
LED: light-emitting diode
LVDS: low voltage differential signaling
MDR: mini D ribbon
NI: National Instruments
NIR: near infrared
NTSC: National Television System(s) Committee
OEM: original equipment manufacturer
OPR: Operational Setting, the basic preset control parameter for SUI cameras.
PAL: non-compliant video standard (Europe/Asia)
PCI: peripheral component interconnect
PDA: Photo Diode Array (each pixel is an active element)
PNUC: parameterized non-uniformity corrections
RMA: return material authorization
QE: quantum efficiency
SDR: shrunk delta ribbon (cable connector)
SECAM: non-compliant video standard (Europe/Asia)
SLR: single lens reflex
SMA: sub-miniature A (RF connector)
SUI: Sensors Unlimited, Inc.
SUI:IA: SUI-Image Analysis freeware program for NI card set.
SWaP: size, weight, and power
SWIR: shortwave infrared
TBD: to be determined
TTL: transistor-transistor logic (digital signaling standard)
TEC: thermoelectric cooler
UTAS: United Technologies Aerospace Systems
UTC: United Technologies Corporation

APPENDIX A: Camera Command Summary

5.5.1.	Restore Factory Configuration	CONFIG:RESET	30
5.5.2.	Save Global Configuration	CONFIG:SAVE	30
5.5.3.	Load Operational Configuration	OPR opr_number	30
5.5.4.	Get Current Operational Configuration Number	OPR?	31
5.5.5.	Get Total Number of Operational Configurations	OPR:MAX?	31
5.5.6.	Set Startup Operational Configuration	OPR:START opr_number	31
5.5.7.	Get Startup Operational Configuration	OPR:START?	32
5.5.8.	Create New Operational Configuration	OPR:SAVE	32
5.5.9.	Update Existing Operational Configuration	OPR:UPDATE	33
5.5.10.	Delete Last Operational Configuration	OPR:DEL	33
5.5.11.	Delete All Operational Configurations	OPR:DEL:ALL	34
5.6.1.	Set Current Baud Rate	BAUD:CURRENT baud_rate	34
5.6.2.	Get Current Baud Rate	BAUD:CURRENT?	35
5.6.3.	Set Future Baud Rate	BAUD:FUTURE baud_rate	35
5.6.4.	Get Future Baud Rate	BAUD:FUTURE?	36
5.6.5.	Set Echo Mode	ECHO:MODE mode	36
5.6.6.	Get Echo Mode	ECHO:MODE?	37
5.6.7.	Set Echo Character	ECHO:CHAR value	37
5.6.8.	Get Echo Character	ECHO:CHAR?	38
5.6.9.	Set Response Mode	RESPONSE mode	38
5.7.1.	Set Gain Correction State	CORR:GAIN state	39
5.7.2.	Get Gain Correction State	CORR:GAIN?	39
5.7.3.	Set Offset Correction State	CORR:OFFSET state	40
5.7.4.	Get Offset Correction State	CORR:OFFSET?	40
5.7.5.	Set Global Corrected Offset Value	CORR:OFFSET:GLOBAL value	40
5.7.6.	Get Global Corrected Offset Value	CORR:OFFSET:GLOBAL?	41
5.8.1.	Set Pixel Substitution State	CORR:PIXEL state	41
5.8.2.	Get Pixel Substitution State	CORR:PIXEL?	42
5.8.3.	User Pixel Defect Flag	PIX:RPL parameters	42
5.8.4.	User Pixel Defect Flag Count	PIX:BAD?	43
5.8.5.	Set Correction Bypass State	CORR:BYPASS state	43
5.8.6.	Get Correction Bypass State	CORR:BYPASS?	44
5.8.7.	Set Pixel Substitution Map State	CORR:PIXEL:MAP state	44
5.8.8.	Get Pixel Substitution Map State	CORR:PIXEL:MAP?	44
5.8.9.	Perform In-Field Dark Offset Operation	CORR:OFFSET:CAL arguments	45
5.9.1.	Set AGC State	AGC:ENABLE state	48
5.9.2.	Get AGC State	AGC:ENABLE?	49
5.9.3.	Set AGC Low Operational Setting	AGC:OPR:LOW opr_setting	49
5.9.4.	Get AGC Low Operational Setting	AGC:OPR:LOW?	49
5.9.5.	Set AGC High Operational Setting	AGC:OPR:HIG ^H opr_setting	50
5.9.6.	Get AGC High Operational Setting	AGC:OPR:HIG ^H ?	50
5.10.1.	Set Enhancement State	ENH:ENABLE state	52
5.10.2.	Get Enhancement State	ENH:ENABLE?	52
5.10.3.	Set Automatic Enhancement State	ENH:AUTO state	52
5.10.4.	Get Automatic Enhancement State	ENH:AUTO?	53
5.10.5.	Set Enhancement/AGC Frame Average and Width Weight	ENH:AVG value	53
5.10.6.	Get Enhancement/AGC Frame Average Weight	ENH:AVG?	53

5.10.7.	Set Enhancement Power Function	ENH:POWER <i>value</i>	54
5.10.8.	Get Enhancement Power Function	ENH:POWER?	54
5.11.1.	Get Pixel Clock Maximum Rate	PIXCLK:MAX?	55
5.12.1.	Set Exposure Period	EXP <i>value</i>	55
5.12.2.	Get Exposure Period	EXP?	56
5.12.3.	Set Frame Period	FRAME:PERIOD <i>value</i>	56
5.12.4.	Get Frame Period	FRAME:PERIOD?	56
5.13.1.	Set Trigger Mode	TRIG:MODE <i>mode</i>	60
5.13.2.	Get Trigger Mode	TRIG:MODE?	60
5.13.3.	Set Trigger Source Mode	TRIG:SOURCE <i>value</i>	61
5.13.4.	Get Trigger Source Mode	TRIG:SOURCE?	61
5.13.5.	Set Trigger Polarity	TRIG:POL <i>value</i>	62
5.13.6.	Get Trigger Polarity	TRIG:POL?	62
5.13.7.	Set Trigger Delay	TRIG:DELAY <i>value</i>	63
5.13.8.	Get Trigger Delay	TRIG:DELAY?	63
5.14.1.	Set Digital Gain	GAIN:DIGITAL <i>value</i>	64
5.14.2.	Get Digital Gain	GAIN:DIGITAL?	64
5.15.1.	Get System Temperature	SYSTEM:TEMP? <i>Kelvin</i>	65
5.15.2.	Get FPA Temperature	FPA:TEMP? -or- FPA:TEMP? <i>Kelvin</i>	65
5.15.3.	Get Thermoelectric Cooler Lock Status	TEC:LOCK?	66
5.15.4.	Get Thermoelectric Cooler Setpoint	TEC:SETPOINT?	66
5.15.5.	Set Thermoelectric Cooler State	TEC:ENABLE <i>state</i>	67
5.15.6.	Get Thermoelectric Cooler State	TEC:ENABLE?	67
5.15.7.	Wait for TEC Lock	TEC:WAIT	67
5.16.1.	Set Digital Data Source	DIGITAL:SOURCE <i>source</i>	68
5.16.2.	Get Digital Data Source	DIGITAL:SOURCE?	68
5.17.1.	Get Camera Serial Number	CAMERA:SN?	69
5.17.2.	Get Camera Part Number	CAMERA:PN?	69
5.17.3.	Get Camera Revision	CAMERA:REV?	70
5.17.4.	Get Firmware Part Number	FIRM:PN?	70
5.17.5.	Get Firmware Revision	FIRM:REV?	70
5.17.6.	Get Hardware Revision	VER:HW?	71
5.17.7.	Get Software Revision	VER:SW?	71
5.17.8.	Get Focal Plane Array Serial Number	FPA:SN?	71
5.17.9.	Get Focal Plane Array Number of Columns	FPA:COLS?	71
5.17.10.	Get Focal Plane Array Number of Rows	FPA:ROWS?	72
5.17.11.	Get Elapsed Time Meter	ETM?	72
5.17.12.	Set Application Timer	AP:TIMER <i>mode</i>	73
5.17.13.	Get Application Timer	AP:TIMER?	73
5.17.14.	Get Camera Command List	CMDS? [<i>prefix</i>]	73
5.17.15.	Get Camera Command Description	HELP? <i>command</i>	74
5.17.17.	Reboot Camera	REBOOT	76
5.17.18.	Set Power-Down Detect Flag	PWRDWN	76
5.17.19.	Get Power-Down Detect Flag	PWRDWN?	77
5.17.20.	Set LED State	LED:ENABLE	77
5.17.21.	Get LED State	LED:ENABLE?	77
5.18.1.	Set Binning Mode State	BIN:ENABLE <i>state</i>	78
5.18.2.	Get Binning Mode State	BIN:ENABLE?	78
5.19.1.	Set Test Pattern State	TESTPAT <i>state</i>	79

5.19.2.	Get Test Pattern State	TESTPAT?	80
5.19.3.	Set Frame Stamp	FRAME:STAMP <i>state</i>	80
5.19.4.	Get Frame Stamp State	FRAME:STAMP?	80
5.19.5.	Get Frame Stamp Count	FRAME:STAMP:COUNT?	81
5.20.1.	Play Macro Command	MACRO:PLAY <i>macro_echo</i>	81
5.21.1.	Set Window Column Start Number	WIN:COL:START <i>value</i>	82
5.21.2.	Get Window Column Start Number	WIN:COL:START?	83
5.21.3.	Set Window Column Stop Number	WIN:COL:STOP <i>value</i>	83
5.21.4.	Get Window Column Stop Number	WIN:COL:STOP?	83
5.21.5.	Set Window Row Start Number	WIN:ROW:START <i>value</i>	84
5.21.6.	Get Window Row Start Number	WIN:ROW:START?	84
5.21.7.	Set Window Row Stop Number	WIN:ROW:STOP <i>value</i>	84
5.21.8.	Get Window Row Stop Number	WIN:ROW:STOP?	85
5.21.9.	Set Window Rectangle	WIN:RECT <X1> <X2> <Y1> <Y2>	85
5.21.10.	Get Window Rectangle	WIN:RECT?	85