

Transmitted Light Stage



Transmitted light stage, P/N 122 150



Analyzer



Transmitted light stage P/N 122 150 with Polarization filter P/N 158 500

Advantages

- Transmitted light stage for microscopy applications.
- Cost effective transmitted brightfield illumination.
- Can be directly inserted into the microscope stages of most major microscope manufacturers.
- Small height raises approximately 20 mm above microscope stage.
- Evenly illuminates a diameter of 50 mm.
- Can be used with all flexible light guides with bundle diameters up to 5.0 mm.
- Polarizing filters available (see table below).

Transmitted light stage	Part. No.	Dimension	Suitable SCHOTT light guides
For KL 1500 HAL For KL 300 LED For KL 1600 LED For KL 2500 LED For KL 2500 LCD	122 150	Ø 84 mm	121 101
			171 101
			155 100
			155 101
			155 102

Polarizing filter for transmitted light stage	Part No.	Dimension
Polarization filter	158 500	Turnable polarization filter attachment
Analyzer	158 505	M49 x 0.75
Analyzer	158 510	M52 x 1.0
Other analyzers available from microscope optic vendors		

** and discontinued KL 1500 products (KL 1500 compact, KL 1500 LCD, KL 1500 LED, KL 1500 LED Plus)

Distribution in the UK & Ireland



**Characterisation,
Measurement &
Analysis**

Lambda Photometrics Limited
 Lambda House Batford Mill
 Harpenden Herts AL5 5BZ
 United Kingdom
E: info@lambdaphoto.co.uk
W: www.lambdaphoto.co.uk
T: +44 (0)1582 764334
F: +44 (0)1582 712084



Transmitted light stage

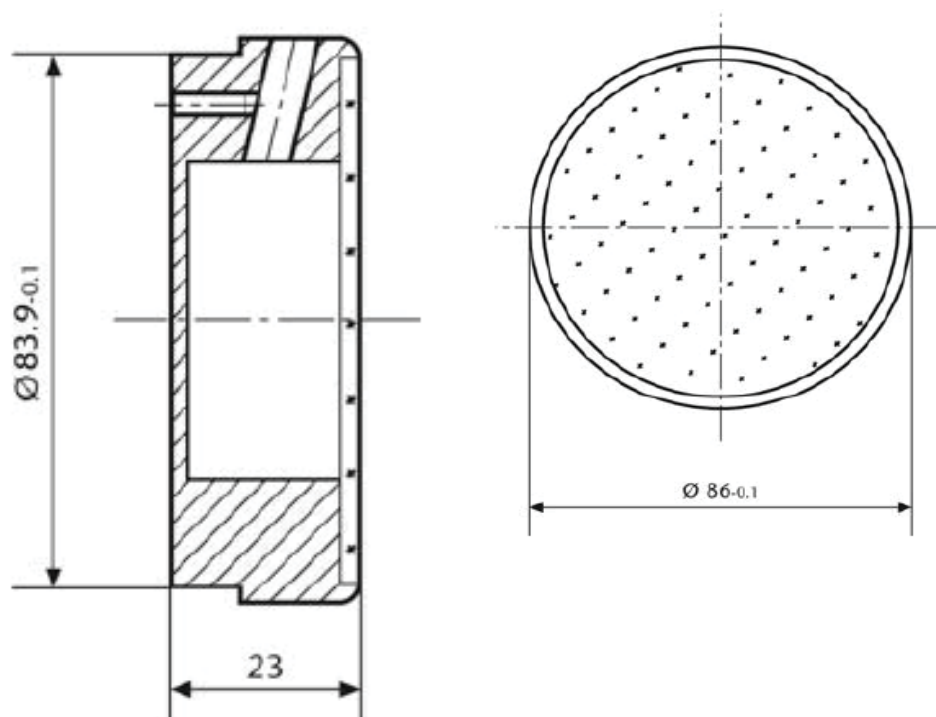

Distribution in the UK & Ireland



Lambda Photometrics Limited
Lambda House Batford Mill
Harpenden Herts AL5 5BZ
United Kingdom

**Characterisation,
Measurement &
Analysis**

E: info@lambdaphoto.co.uk
W: www.lambdaphoto.co.uk
T: +44 (0)1582 764334
F: +44 (0)1582 712084

All specifications are subject to change without prior notice. This datasheet or any extracts thereof may only be used in other publications with express permission of SCHOTT. © SCHOTT AG

SCHOTT
glass made of ideas