

Small Instrumentation Modules

SIM918 — Precision current preamplifier with autozero feature

- **Input offset voltage <math> < 5 \mu\text{V}</math>**
- **DC bias current <math> < 200 \text{ fA}</math>**
- **Current gain of**
-
- **Autozero feature**
- **Bias voltage input**



SIM918 Precision Current Preamplifier

The SIM918 Current Preamplifier is ideal in applications in which the input offset voltage must be kept to a minimum. The DC voltage difference between the two inputs (current input and voltage bias) is accurately measured every 2 seconds, and is nulled. The result is a current amplifier with less than $5 \mu\text{V}$ input offset voltage. This autozeroing feature can be engaged or inhibited remotely or from the front panel, giving you flexibility in sensitive applications.

As a current amplifier, the SIM918 offers input noise as low as $15 \text{ fA}/\sqrt{\text{Hz}}$ and adjustable current gain (10^6 to 10^8 V/A). The output voltage range is $\pm 10 \text{ V}$ for all gain settings. Input bias current is less than 200 fA (DC), and the instrument has up to 10 kHz of (gain-dependent) bandwidth.

There is a voltage bias input for setting the virtual ground potential to an external DC source. This input can range over $\pm 5 \text{ V}$. The bias voltage can be internally grounded.

An autozero sync input/output connection is also provided. In the internal autozeroing mode, this port provides a one pulse-per-second (pps) output synchronous with the internal switching circuitry. In the external mode, a 0.9 to 1.1 pps input signal generates the reference for synchronizing the circuitry.

The SIM918 provides maximum flexibility for cabling and grounding. The shield of the current input BNC can be switched between chassis ground, the bias voltage, or the rear-panel Program input (which can be left floating, if desired). With the Program input, a user can supply an excitation potential to an experiment via the shield conductor of the input cable, while the excited current flows through the center conductor to the SIM918. The shield of the voltage bias BNC can be independently grounded or floated.

The digital control circuitry in the SIM918 is designed with SRS's special clock-stopping architecture in which the microcontroller is turned on only when settings are being

Distribution in the UK & Ireland



**Characterisation,
Measurement &
Analysis**

Lambda Photometrics Limited
Lambda House Bafford Mill
Harpenden Herts AL5 5BZ
United Kingdom
E: info@lambdaphoto.co.uk
W: www.lambdaphoto.co.uk
T: +44 (0)1582 764334
F: +44 (0)1582 712084

SIM918 Precision Current Preamplifier

changed (note that the autozeroing circuitry is independent of the microcontroller, and *can* operate while the digital clock is stopped). This guarantees that no digital noise can contaminate low-level analog signals. Settings may be changed from the front panel or through the remote interface. All instrument settings can also be queried via the remote interface. The module generates a status signal to alert the user of any overload conditions.

SIM918 Specifications

Current Input

Input offset voltage	<5 μV (autozero enabled)
Input impedance	1 k Ω
Current gain	10 ⁶ V/A, 10 ⁷ V/A or 10 ⁸ V/A
Gain accuracy	
(10 ⁶ V/A)	$\pm 0.1\%$
(10 ⁷ V/A)	$\pm 0.1\%$
(10 ⁸ V/A)	$\pm 1.0\%$
Gain stability	
(10 ⁶ V/A)	± 10 ppm/ $^{\circ}\text{C}$
(10 ⁷ V/A)	± 50 ppm/ $^{\circ}\text{C}$
(10 ⁸ V/A)	± 100 ppm/ $^{\circ}\text{C}$
Bandwidth	
(10 ⁶ V/A)	10 kHz
(10 ⁷ V/A)	7 kHz
(10 ⁸ V/A)	4 kHz
Input noise (typ.)	
(10 ⁶ V/A)	150 fA/ $\sqrt{\text{Hz}}$ @ 1 kHz
(10 ⁷ V/A)	50 fA/ $\sqrt{\text{Hz}}$ @ 1 kHz
(10 ⁸ V/A)	15 fA/ $\sqrt{\text{Hz}}$ @ 1 kHz
AC bias current	<2 pA rms (w/ autozero engaged)
DC bias current	<200 fA
Input BNC shield	Can be tied to chassis ground, set to the rear-panel analog input (Prog), or driven from the bias input

Bias Input

Range	± 5 VDC
Frequency response	1 Hz
Input impedance	10 M Ω
Input BNC shield	Ground or float

Program Input (rear panel)

Function	Connects to current input BNC shield when selected (unbuffered)
Range	± 60 V
Input impedance	3 G Ω (typ.)

Output

Range	± 10 V
Max. current	100 mA

Autozero

Function select	On or Hold
Int. switching freq.	0.5 Hz
Ext. sync in/out	1 pulse per second (pps), TTL level. Functions as a 1 pps sync output in internal mode.
Sync capture range	$\pm 10\%$ of 1 pps

General

Operating temperature	0 $^{\circ}\text{C}$ to 40 $^{\circ}\text{C}$, non-condensing
Interface	Serial via SIM interface
Connectors	BNC (3 front, 2 rear)
DB15 (male)	SIM interface
Power	+5 VDC (50 mA max.), ± 15 VDC (50 mA max.)
Dimensions	1.5" \times 3.6" \times 7.0" (WHD)
Weight	1.5 lbs.
Warranty	One year parts and labor on defects in materials and workmanship

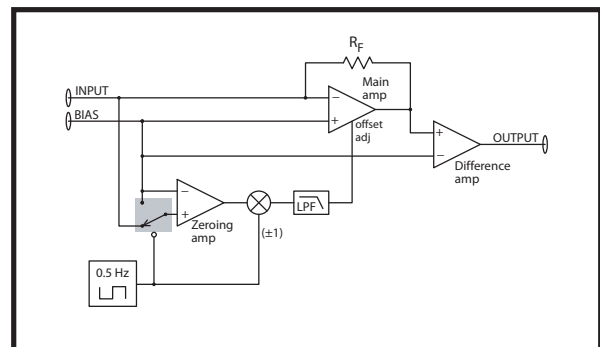

SIM918 Block Diagram

The zeroing amp measures the voltage between INPUT and BIAS, and servos the “offset adjust” of the main amplifier to minimize this difference. A slow chopping scheme is used to compensate for the offset voltage of the zeroing amp itself. The final difference amp subtracts the bias voltage from the main amplifier output, so that the output is proportional to the input current.

Ordering Information

SIM918 Precision current preamplifier

Distribution in the UK & Ireland



Characterisation,
Measurement &
Analysis

Lambda Photometrics Limited
Lambda House Batford Mill
Harpenden Herts AL5 5BZ
United Kingdom

E: info@lambdaphoto.co.uk
W: www.lambdaphoto.co.uk
T: +44 (0)1582 764334
F: +44 (0)1582 712084