

TA138 200 A AC Current Clamp



OPERATING INSTRUCTIONS

Introduction

The TA138 200 A AC Current Clamp has a voltage output with standard banana (4 mm) plugs for connection to the PicoLog CM3 Current Data Logger or other compatible measuring instrument.

Using the Current Clamp Safely

Warning: To prevent electric shock or fire and personal injury, carefully read all safety information before attempting to operate the Current Clamp and follow these procedures:

- **DO NOT** use the clamp on circuits rated higher than 600 V in Category II or 300 V in Category III. Use caution when clamping around uninsulated conductors or bus bars.
- **DO NOT** use a clamp that is cracked, damaged, or has a defective cable. Such clamps should be made inoperative by taping the jaws closed.
- **DO** check the magnetic mating surfaces of the clamp jaws. They should be free of dust, dirt, rust and other foreign matter.
- **DO** keep your fingers behind the safety barrier as shown below.

Safety Symbols



This symbol, adjacent to another symbol or terminal, indicates that the user must refer to the manual for further information.



This symbol, adjacent to a terminal, indicates that, under normal use, hazardous voltages may be present.

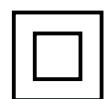

Double insulation

Adaptor Description

1. Current sense jaw
2. Clamp trigger
3. Safety barrier
4. Voltage output lead

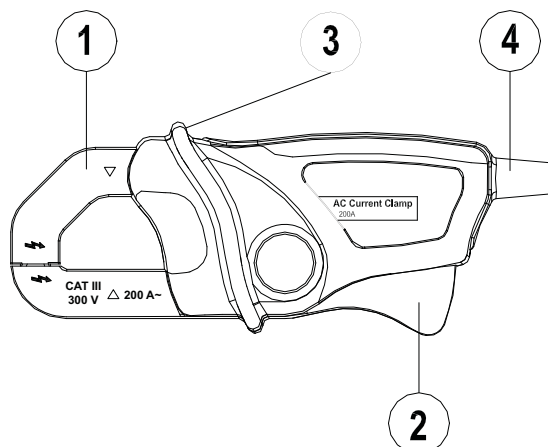

Distribution in the UK & Ireland



Lambda Photometrics Limited
Lambda House Batford Mill
Harpenden Herts AL5 5BZ
United Kingdom
E: info@lambdaphoto.co.uk
W: www.lambdaphoto.co.uk
T: +44 (0)1582 764334
F: +44 (0)1582 712084

Characterisation,
Measurement &
Analysis

Specifications

● General Specifications

Output impedance	<1 k Ω
AC bandwidth	40 to 400 Hz
Jaw opening	16 mm
Operating conditions	32 °F to 86 °F (0 °C to 30 °C) 90% RH; 86 °F to 104 °F (30 °C to 40 °C) 75% RH; 104 °F to 122 °F (40 °C to 50 °C) 45% RH
Storage conditions	-22 °F to 140 °F (-30 °C to 60 °C) <90% RH
Altitude	Operate at less than 3000 metres
Weight	129 g
Dimensions	111 x 50 x 33 mm (H x W x D)
Standards	IEC1010-1 (1995); EN61010-1 (2001) Category II 600 V, Category III 300 V

● Range Specifications

Function	Range	Output	Sensitivity	Accuracy (of reading)
AC Current (50/60 Hz)	0 to 200 A	1 mV/A	1 A/mV AC	$\pm 2.0\% \pm 0.5$ A

Using the Current Clamp with the PicoLog Software

1. Connect the output lead to the input sockets of the PicoLog CM3 Current Data Logger.
2. Connect the PicoLog CM3 to your computer using the USB cable supplied.
3. Position the Current Clamp perpendicular to and centered around the conductor.
4. Run the PicoLog software on the computer.
5. Select **File > New Settings** and configure PicoLog for a 'PLCM3' device.
6. Select **File > New Data** and click the 'Start recording' button when ready.

