

## Fiber Phase Shifter (FPS-001)

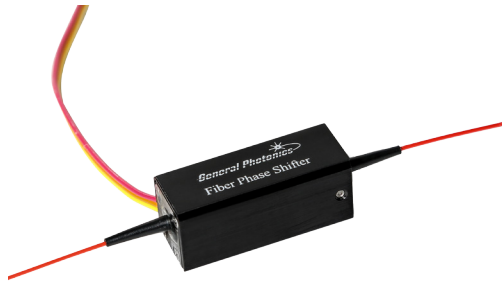

General Photonics' all fiber phase shifter/modulator provides phase shifts up to  $15\pi$  at frequencies from DC to 20 kHz. The all fiber construction practically eliminates insertion loss and back reflection. This compact device is ideal for fiber laser systems, fiber resonators, and fiber interferometers for precision phase tuning or phase modulation.

### Specifications:

Insertion Loss	< 0.1 dB
Return Loss	> 65 dB
Total Phase Shift (0 – 20 kHz)	> $8\pi$
Half-wave Voltage (0 – 20 kHz)	< 20 V
Operating Wavelength	1260 to 1650 nm or 980 to 1310 nm standard
PDL	< 0.05 dB
Residual Amplitude Modulation	$\pm 0.01$ dB
Operating Temperature	0 to 50 °C
Storage Temperature	-40 to 85 °C
Max. Applied Voltage	150 volts
Dimensions	Pigtailed: 1.38" (L) × 0.55" (W) × 0.55" (H) NoTail™: 2.90" (L) × 0.55" (W) × 0.55" (H)
<p>Note: Specifications in this table are for devices with SM fiber, without connectors. Information for devices with other types of fiber is available on request.</p>	

### Features:

- Compact size
- Low insertion loss
- Low residual amplitude modulation
- Low PDL
- Low cost
- NoTail™ model available

### Applications:

- Fiber interferometers
- Fiber laser systems
- Fiber sensor systems

### Related Products

- Phase Shifters (FPS-002, FPS-003)

### FAQ:

- Phase Shifters

### Dimensions (in inches):

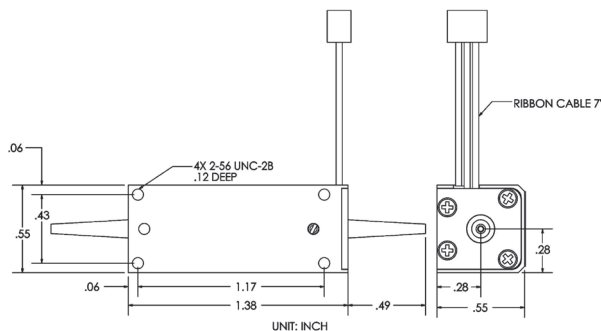

### Ordering Information:

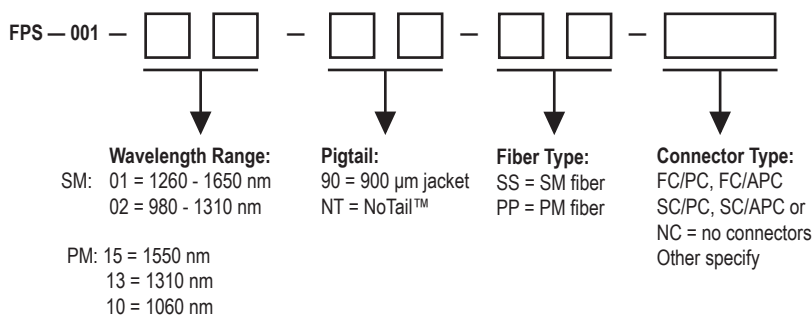

Distribution in the UK & Ireland



**Lambda Photometrics Limited**  
 Lambda House Batford Mill  
 Harpenden Herts AL5 5BZ  
 United Kingdom  
**E:** [info@lambdaphoto.co.uk](mailto:info@lambdaphoto.co.uk)  
**W:** [www.lambdaphoto.co.uk](http://www.lambdaphoto.co.uk)  
**T:** +44 (0)1582 764334  
**F:** +44 (0)1582 712084