



### Device Information

Model Name	VCXU.2-15M
Vendor Name	Baumer

### Sensor Information

Sensor Name	Sony IMX273 Gen2
Type	1/2.9" progressive scan CMOS
Shutter	Global Shutter
Resolution	1440 x 1080 pixels
Scan Area	4.96 mm x 3.72 mm
Pixel Size	3.45 µm x 3.45 µm

### Data Quality

@ 20 °C, gain = 1, exposure time = 4 msec

Dark Noise ( $\sigma$ )	2 e- typical
Saturation	9500 e- typical
Dynamic Range	71 dB typical
SNR	40 dB typical
Quantum efficiency $\eta$	64% @ 536 nm typical

### Acquisition

Resolution	1440 px x 1080 px		
Interface Frame Rate (depends on used interface performance)	Format	Resolution	max. Frame Rate (@ Trigger Mode) <sup>2)</sup>
	Full Frame	1440 x 1080	225 fps
	Binning 2x2	720 x 540	504 fps
	Binning 2x1	720 x 1080	225 fps
	Binning 1x2	1440 x 540	225 fps
Acquisition Frame Rate <sup>1)</sup>	227 fps   $t_{\text{readout}} = 4.4 \text{ msec}$ (max. Res. Full Frame) @ 10 bit		
	166 fps   $t_{\text{readout}} = 6.01 \text{ msec}$ (max. Res. Full Frame) @ 12 bit		
	508 fps   $t_{\text{readout}} = 1.97 \text{ msec}$ (max. Res. Binning 2x2) @ 10 bit		
	320 fps   $t_{\text{readout}} = 3.12 \text{ msec}$ (max. Res. Binning 2x2) @ 12 bit		
Pixel Formats	Mono8, Mono10, Mono12, Mono12p		
Partial Scan	True Partial Scan with increasing Frame Rate on Y direction, Region of Interest (ROI) arbitrary		
	Width: minimum 32, increment 32		
	Height: minimum 1, increment 1		
Adjustable Acquisition Frame Rate	Off or 0.01 ... 65535 Hz		
Acquisition Mode	Continuous, Single Frame and Multi Frame		
Acquisition Status	AcquisitionActive, AcquisitionTrigger Wait		
Exposure Mode	Timed		
Shutter Mode	Global		
Readout Mode	Overlapped, Sequential		

Sensor Graph: Relative Response

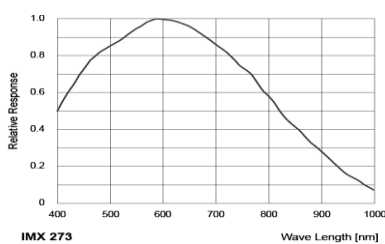

Digital Output: High Active

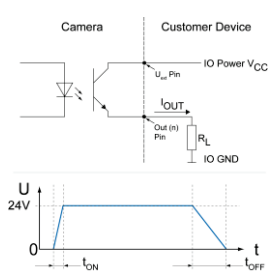

Distribution in the UK & Ireland



**Lambda Photometrics Limited**  
Lambda House Batford Mill  
Harpenden Herts AL5 5BZ  
United Kingdom  
E: [info@lambdaphoto.co.uk](mailto:info@lambdaphoto.co.uk)  
W: [www.lambdaphoto.co.uk](http://www.lambdaphoto.co.uk)  
T: +44 (0)1582 764334  
F: +44 (0)1582 712084

### Image Pre-Processing

Analog Controls	Exposure Time (1 µsec ... 60 sec   Step Size 1 µsec) Gain (0...48 dB), Offset (0 ... 255 LSB   12 bit)
Auto Function	ExposureAuto and GainAuto with BrightnessAutoPriority based on BrightnessAuto ROI
Gamma Correction	Gamma (0.1 ... 2   available if LUT is enabled)
LUT	Luminance (12 bit)
Color Models	Mono
Color Processing	-
Color Enhancement	-

<sup>1)</sup> Sensor readout, different from pixel format

<sup>2)</sup> depends on the used interface

### Digital Output: Low Active

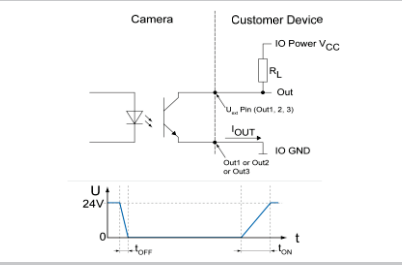

### Digital Input

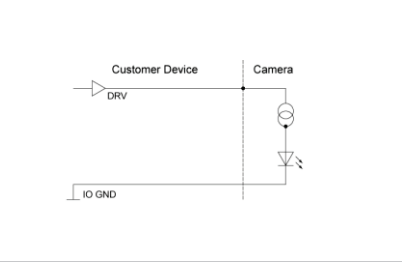

### Trigger Mode: Start up time and valid Trigger

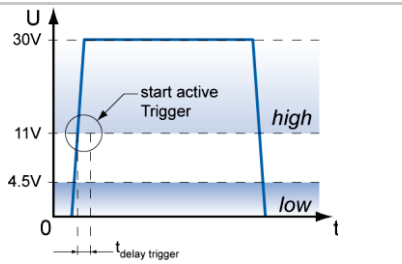

### GPIO

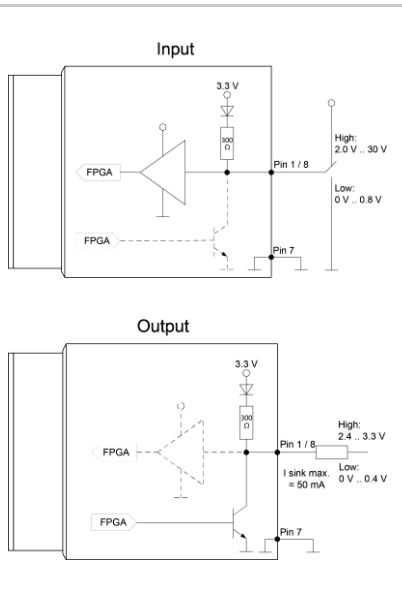

## Image Pre-Processing

Color Tolerance	-
Binning Horizontal	1 or 2
Binning Vertical	1 or 2
Defect Pixel Correction	via Defect Pixel List with up to 512 Pixel Coordinates
Image Flipping	Horizontal, vertical
Fix Pattern Noise	-
Correction	-

## Process Synchronization

Trigger Mode	Off (Free Running), On (Trigger)
Trigger Overlap Type	Readout
Trigger Sources	Hardware (Line0, 1, 2), Software, Counter 1, 2 End, All or Off fixed Trigger Delay out of treadout: <sup>1)</sup> 44.8 µsec @ 10 bit 49.1 µsec @ 12 bit max. Trigger Delay during treadout: <sup>1)</sup> 43.7 µsec @ 10 bit 49.4 µsec @ 12 bit
Trigger Delay	0 ... 2 sec, Tracking and buffering of up to 256 triggers
External Flash Sync	via Exposure Active $t_{\text{delay flash}} \leq 3 \mu\text{sec}$ , $t_{\text{duration}} = t_{\text{exposure}}$
Encoder Function	yes, via Counter and Trigger Source
PTP Function	-

## Digital I/Os

Lines	Input: Line 0, Output: Line3, GPIO: Line 1, Line 2
Line Sources (Output)	Off, ExposureActive, Timer1, ReadoutActive, UserOutput 1-3 and TriggerReady
Line Debouncer (Input)	Low and high signal separately selectable Debouncing Time 0 ... 5 msec, Step Size: 1 µsec

## Memory

Image Buffer	428 MB 96 Images (Trigger Mode) / 1 Image (Free Running Mode)
Non-volatile Memory	128 kb

## Interface Data

Interface	USB3.0 (5000 Mbits/sec)
USB Vendor ID / Product ID	0x2825 / 0x0171

## USB 3 Vision® Features

Events Transmission via Asynchronous Message Channel	DeviceTemperatureStatusChanged, EventLost, ExposureEnd, ExposureStart, FrameEnd, FrameStart, FrameTransferSkipped, Line0..2 FallingEdge, Line0..2 RisingEdge, TransferBufferFull, TransferBufferReady, TriggerOverlapped, TriggerReady, TriggerSkipped
Frame Counter	up to 2 <sup>32</sup>
Payload Size	0 ... 3110624 Byte
Timestamp	64 bit, resolution in nsec, increment = 8
USB Vision	v1.0.1

## Interfaces and Connectors

Data and Power Interface	USB 3.0 Transfer Rate 5000 Mbits/sec	USB 2.0 Transfer Rate 480 Mbits/sec
Connector:	USB 3.0 Micro B	
Pin Assignment:	1 - VBUS 3 - D+ 5 - GND 7 - MicB_SSTX+ 9 - MicB_SSRX-	2 - D- 4 - ID 6 - MicB_SSTX- 8 - GND_DRAIN 10 - MicB_SSRX+

<sup>1)</sup> Sensor readout, different from pixel format

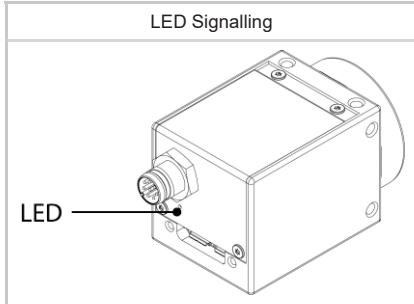
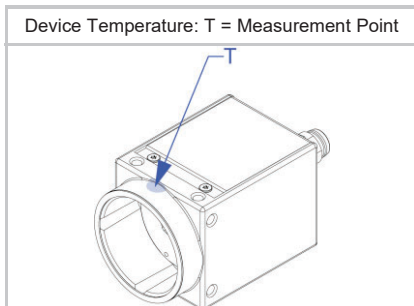
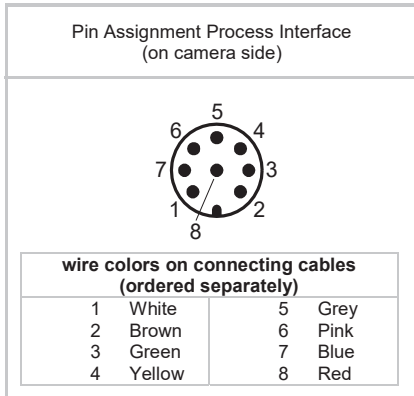
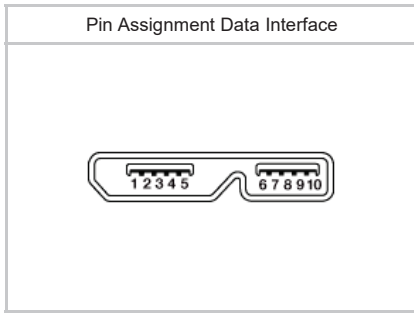

## Interfaces and Connectors

Process Interface	Connector:	M8/8-pin (SACC-DSI-M8MS-8CON-M8-L180)
	Assignment:	1 - GPIO (Line2) 2 - not connected 3 - IN1 (Line0) 4 - GND IN1 5 - Power VCC 6 - OUT1 (Line3) OUT1 8 - GPIO (Line1) 7 - GND GPIO

Caution



\* Note GPIOs: Ground loops are to be avoided and can lead to destruction of the device.

## Optical Data

Lens Mount	C-Mount
Optical Filter	-

## Mechanical Data

Housing	Zinc die casting, baked varnish
Protection Class	IP40 (with mounted lens and USB 3.0 cable)
Weight	90 g
Dimensions	

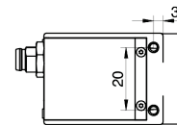
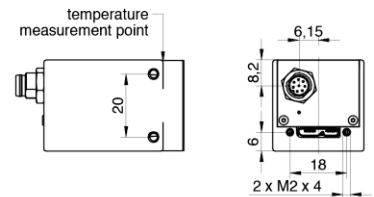
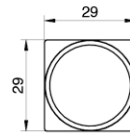
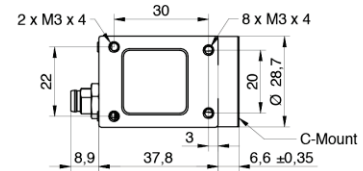

## Environmental Data

Storage Temperature	-10 °C ... +70 °C
Operating Temperature	0 °C ... +65 °C @ T = Measurement Point or 0 °C ... +72 °C @ internal Temperature Sensor Note: Ambient temperature above 28 °C requires heat dissipation measures.
Int. Temperature Sensor	yes, accuracy: ±1 °C (typ) 0 °C ... +85 °C
Humidity	10 % ... 90 % non-condensing

<sup>1)</sup> the maximum temperature for Sony sensor characteristics (sensor performance) are guaranteed up to 50 °C @ Measurement Point or up to 56 °C @ internal temperature sensor

## LED Signalling

LED	Green flash	Power on, no link active
	Green	Link active USB 3.0
	Red	Error or Link active USB 2.0
	Yellow	Sensor Readout activity
	Red flash	Update

## Electrical Data

Power Supply	bus powered via USB3.0 interface
Power Consumption	approx. 2.9 W @ 225 fps (Factory Setting "Default")
Digital Input	Optocoupler $U_{IN(low)}$ : 0.0 ... 4.5 VDC $U_{IN(high)}$ : 11.0 ... 30.0 VDC $I_{IN}$ : 3.0 ... 10.0 mA min. Impulse Length: 2.0 $\mu$ sec
Digital Output	Optocoupler $U_{EXT}$ : 5 ... 30 V DC $I_{OUT}$ : max. 50 mA $t_{ON}$ = typ. 3 $\mu$ sec $t_{OFF}$ = typ. 40 $\mu$ sec
GPIO	direct, without optocoupler
GPIO used as Input:	$U_{IN(low)}$ : 0.0 ... 0.8 VDC $U_{IN(high)}$ : 2.0 ... 30.0 VDC min. Impulse Length: 2.0 $\mu$ sec
GPIO used as Output:	$U_{Out(low)}$ : 0.0 ... 0.4 VDC ( $I_{sink\ max}$ : 50 mA) $U_{Out(high)}$ : 2.4 ... 3.3VDC ( $I_{max}$ : 1 mA)
Caution 	* The General Purpose I/Os (GPIOs) are not potential-free and do not have an overrun cut-off. Incorrect wiring (overvoltage, undervoltage or voltage reversal) can lead to defects in the electronic system. Ground loops are to be avoided and can lead to destruction of the device.

## Conformity

Conformity	CE, RoHS, REACH
KC Registration No. / Date	- / -
MTBF	60 years @ T = 45 °C / 39 years @ T = 60 °C T = Measurement Point

## GeniCam™ Features

Short Exposure Range	yes, ShortExposureTimeEnable Short Exposure Range 1 $\mu$ sec ... 60 sec Default Exposure Range 15 $\mu$ sec ... 60 sec
Timer	Timer Selector: Timer Selector: Timer 1 TimerTriggerSource: Line0, SoftwareTrigger, ExposureStart, ExposureEnd, FrameTransferSkipped, TriggerSkipped, Off TimerDelay: 0 $\mu$ sec ... 2 sec, Step Size: 1 $\mu$ sec TimerDuration: 4 $\mu$ sec ... 2 sec, Step Size: 1 $\mu$ sec
Counter	Counter Selector: Counter 1, Counter 2 CounterValue: 0 ... 65535 Counter Event Source: Counter1End or Counter2End, ExposureActive, FrameTransferSkipped, FrameTrigger, TriggerSkipped, Line0..2 and Off Counter Reset Source: Counter1End, Counter2End, Line0..2 and Off
Sequencer	Sequencer Characteristics: up to 128 sets, up to 4 possible pathes for triggered set transitions, 6 trigger sources: Counter1End, Counter2End, ExposureActive, Line0..2, ReadoutActive, Timer1End Sequencer Parameters for Exposure, Gain, Trigger, ROI and Output: ExposureTime, CounterDuration, CounterEventActivation, CounterEventSource, CounterResetSource, ExposureMode, ExposureTime, Gain, Height, OffsetX, OffsetY, TriggerMode, UserOutputValue, UserOutputValueAll, Width

## GenICam™ Features

User Sets	Factory Settings: UserSet0 (read only) Freely Programmable: UserSet1, UserSet2, UserSet3 Parameters: any user definable Parameter
Acquisition Abort	Delay up to 6.1 msec
Chunk Data	yes, Chunk Selector: Binning, BlackLevel, CounterValue, DeviceTemperature, ExposureTime, FrameID, Gain, Height, Image, ImageControl, LineStatusAll, OffsetX, OffsetY, PixelFormat, SequencerSetActive, Timestamp, Width
Device Temperature	InHouse Event generation for Normal to High, High to Exceeded and Exceeded to Normal Exceeded (no image transfer) = max. internal temperature sensor + 1 °C
Device Link Throughput Limit	yes, up to max. Device Link Speed
Custom Data	yes, 128 Byte with CustomDataKonfiguration Mode
Calibration Data	yes, camera calibration values can stored: CalibrationMatrix, CalibrationMatrixNew, CalibrationFocalLenght, CalibrationAngularAperture, GeometryDistortionValue: k1, k2, p1, p2, k3, CalibrationVector: tvec, rvec and CalibrationDataVersion
SFNC Version	2.4.0

## Factory Settings after Start-Up

Trigger Mode	Off (Free Running)
Analog Controls	Exposure Time: 4 msec, Gain: 0 dB, Offset: 0
Pixel Format	Mono8
Partial Scan	Off
Acquisition Frame Rate	Off
Timer/Counter/Sequencer	Off
Defect Pixel Correction	ON
Fixed Pattern Noise Correction	-
Digital Input	Line0, invert = false
Digital Output	Line3, invert = false, line source = Off
GPIO 1/2	Line1, Line2, invert = false, LineMode = Input
TriggerSource	All

**Partial Scan** @ FullFrame, min Exposure, Mono8 (monochrome camera) or BayerRG8 (color camera)

	Resolution	max. fps acquisition	max. fps interface <sup>2)</sup>
SXGA	1280 x 1024	238	238
HD720	1280 x 720	332	332
XGA	1024 x 768	313	313
SVGA	800 x 600	394	394
VGA	640 x 480	483	483
CIF	352 x 288	759	759
QVGA	320 x 240	886	886
QCIF	176 x 144	1327	1327
LineScan	1440 x 1024	238	238
	1440 x 512	456	456
	1440 x 256	839	839
	1440 x 128	1448	1448
	1440 x 64	2271	2271
	1440 x 32	3173	3173
	1440 x 16	3960	3960
	1440 x 8	4520	4520
	1440 x 4	4864	4864
	1440 x 2	5056	5056
	1440 x 1	5158	5158

<sup>2)</sup> depends on the used interface

Distribution in the UK & Ireland



**Characterisation,  
Measurement &  
Analysis**

**Lambda Photometrics Limited**  
Lambda House Batford Mill  
Harpenden Herts AL5 5BZ  
United Kingdom  
**E: [info@lambdaphoto.co.uk](mailto:info@lambdaphoto.co.uk)**  
**W: [www.lambdaphoto.co.uk](http://www.lambdaphoto.co.uk)**  
**T: +44 (0)1582 764334**  
**F: +44 (0)1582 712084**