



### Device Information

Model Name	VCXU.2-123C
Vendor Name	Baumer

### Sensor Information

Sensor Name	Sony IMX253 Gen2
Type	1.1" progressive scan CMOS
Shutter	Global Shutter
Resolution	4096 x 3000 pixels
Scan Area	14.13 mm x 10.35 mm
Pixel Size	3.45 $\mu\text{m}$ x 3.45 $\mu\text{m}$

### Data Quality

@ 20 °C, gain = 1, exposure time = 4 msec

Dark Noise ( $\sigma$ )	2 e- typical
Saturation	9500 e- typical
Dynamic Range	71 dB typical
SNR	40 dB typical
Quantum efficiency $\eta$	48% @ 465 nm, 58% @ 536 nm, 54% @ 631 nm typical

### Acquisition

Resolution	4096 px x 3000 px		
Interface Frame Rate (depends on used interface performance)	Format	Resolution	max. Frame Rate (@ Trigger Mode) <sup>2)</sup>
	Full Frame	4096 x 3000	31 fps
	Binning 2x2	2048 x 1500	31 fps
	Binning 2x1	2048 x 3000	31 fps
	Binning 1x2	4096 x 1500	31 fps

Acquisition Frame Rate <sup>1)</sup>	31 fps   $t_{\text{readout}} = 31.8 \text{ msec}$ (max. Res. Full Frame) @ 10 bit
	29 fps   $t_{\text{readout}} = 34.5 \text{ msec}$ (max. Res. Full Frame) @ 12 bit

Pixel Formats	BayerRG8, BayerRG10, BayerRG12, BayerRG12p Mono8, Mono10, Mono12, Mono12p, RGB8, BGR8
---------------	--

Partial Scan	True Partial Scan with increasing Frame Rate on Y direction, Region of Interest (ROI) arbitrary
--------------	---

Adjustable Acquisition Frame Rate	Off or 0.01 ... 65535 Hz
-----------------------------------	--------------------------

Acquisition Mode	Continuous, Single Frame and Multi Frame
Acquisition Status	AcquisitionActive, AcquisitionTrigger Wait
Exposure Mode	Timed
Shutter Mode	Global
Readout Mode	Overlapped, Sequential

Sensor Graph: Relative Response

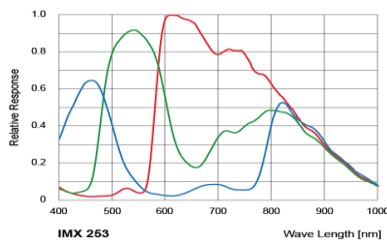

Digital Output: High Active

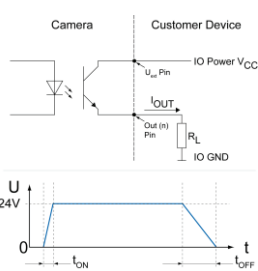

Distribution in the UK & Ireland



**Lambda Photometrics Limited**  
 Lambda House Batford Mill  
 Harpenden Herts AL5 5BZ  
 United Kingdom  
**E:** [info@lambdaphoto.co.uk](mailto:info@lambdaphoto.co.uk)  
**W:** [www.lambdaphoto.co.uk](http://www.lambdaphoto.co.uk)  
**T:** +44 (0)1582 764334  
**F:** +44 (0)1582 712084

<sup>1)</sup> Sensor readout, different from pixel format

<sup>2)</sup> depends on the used interface

### Image Pre-Processing

Analog Controls	Exposure Time (1 $\mu\text{sec}$ ... 60 sec   Step Size 1 $\mu\text{sec}$ ) Gain (0...48 dB), Offset (0 ... 255 LSB   12 bit)
Auto Function	ExposureAuto and GainAuto with BrightnessAutoPriority based on BrightnessAuto ROI BalanceWhiteAuto and ColorTransformationAuto based on BalanceWhiteAuto ROI
Gamma Correction LUT	Gamma (0.1 ... 2   available if LUT is enabled) Luminance (12 bit)
Color Models	Mono, Raw Bayer, RGB and BGR
Color Processing	Integrated color processor for high quality color calculation
Color Enhancement	Color Transformation to sRGB color space by optimized Matrix for 3000 K, 5000 K, 6500 K and 9500 K Lightsource or User defined Matrix

### Digital Output: Low Active

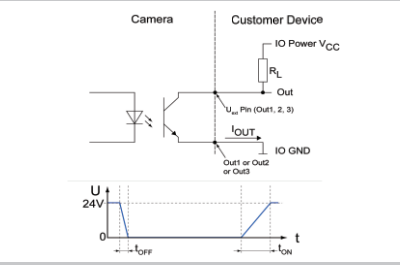

### Digital Input

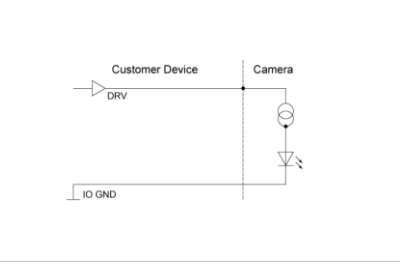

### Trigger Mode: Start up time and valid Trigger

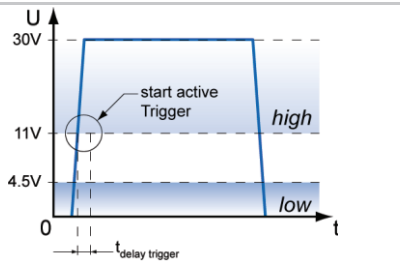

### GPIO

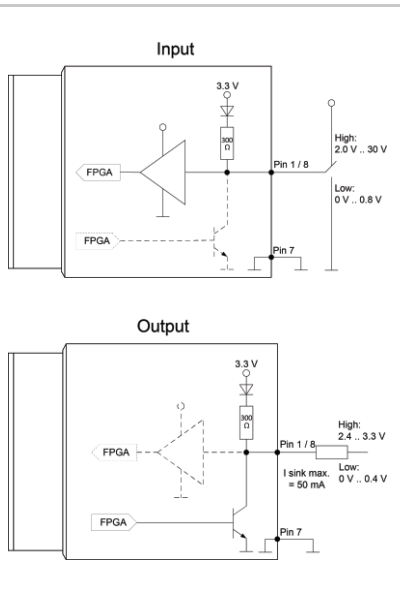

## Image Pre-Processing

Color Tolerance	-
Binning Horizontal	1 or 2
Binning Vertical	1 or 2
Defect Pixel Correction	via Defect Pixel List with up to 512 Pixel Coordinates
Image Flipping	Horizontal, vertical
Fix Pattern Noise	-
Correction	-

## Process Synchronization

Trigger Mode	Off (Free Running), On (Trigger)
Trigger Overlap Type	Readout
Trigger Sources	Hardware (Line0, 1, 2), Software, Counter 1, 2 End, All or Off fixed Trigger Delay out of treadout: <sup>1)</sup> 64.4 μsec @ 10 bit 66.9 μsec @ 12 bit max. Trigger Delay during treadout: <sup>1)</sup> 69.6 μsec @ 10 bit 73 μsec @ 12 bit
Trigger Delay	0 ... 2 sec, Tracking and buffering of up to 256 triggers
External Flash Sync	via Exposure Active $t_{\text{delay flash}} \leq 3 \mu\text{sec}$ , $t_{\text{duration}} = t_{\text{exposure}}$
Encoder Function	yes, via Counter and Trigger Source
PTP Function	-

## Digital I/Os

Lines	Input: Line 0, Output: Line3, GPIO: Line 1, Line 2
Line Sources (Output)	Off, ExposureActive, Timer1, ReadoutActive, UserOutput 1-3 and TriggerReady
Line Debouncer (Input)	Low and high signal separately selectable Debouncing Time 0 ... 5 msec, Step Size: 1 μsec

## Memory

Image Buffer	458 MB 13 Images (Trigger Mode) / 1 Image (Free Running Mode)
Non-volatile Memory	128 kb

## Interface Data

Interface	USB3.0 (5000 Mbits/sec)
USB Vendor ID / Product ID	0x2825 / 0x0171

## USB 3 Vision® Features

Events Transmission via Asynchronous Message Channel	DeviceTemperatureStatusChanged, EventLost, ExposureEnd, ExposureStart, FrameEnd, FrameStart, FrameTransferSkipped, Line0..2 FallingEdge, Line0..2 RisingEdge, TransferBufferFull, TransferBufferReady, TriggerOverlapped, TriggerReady, TriggerSkipped
Frame Counter	up to 2 <sup>32</sup>
Payload Size	0 ... 36864224 Byte
Timestamp	64 bit, resolution in nsec, increment = 10
USB Vision	v1.0.1

## Interfaces and Connectors

Data and Power Interface	USB 3.0 Transfer Rate 5000 Mbits/sec	USB 2.0 Transfer Rate 480 Mbits/sec
Connector:	USB 3.0 Micro B	
Pin Assignment:	1 - VBUS 3 - D+ 5 - GND 7 - MicB_SSTX+ 9 - MicB_SSRX-	2 - D- 4 - ID 6 - MicB_SSTX- 8 - GND_DRAIN 10 - MicB_SSRX+

<sup>1)</sup> Sensor readout, different from pixel format

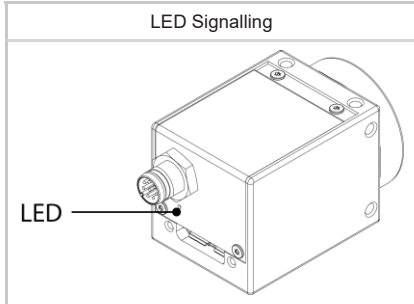
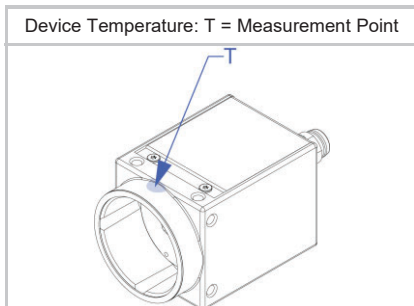
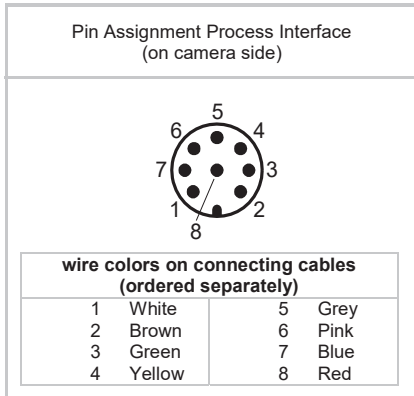
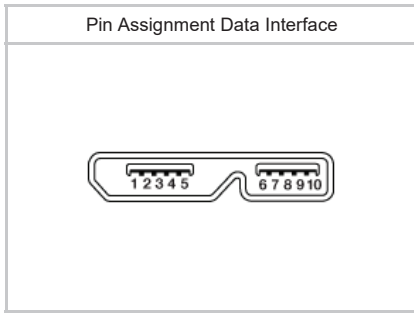

## Interfaces and Connectors

Process Interface	Connector:	M8/8-pin (SACC-DSI-M8MS-8CON-M8-L180)
	Assignment:	1 - GPIO (Line2)    2 - not connected 3 - IN1 (Line0)    4 - GND IN1 5 - Power VCC    6 - OUT1 (Line3) OUT1    8 - GPIO (Line1) 7 - GND GPIO

Caution



\* Note GPIOs: Ground loops are to be avoided and can lead to destruction of the device.

## Optical Data

Lens Mount	C-Mount
Optical Filter	IR cut filter

## Mechanical Data

Housing	Zinc die casting, baked varnish
Protection Class	IP40 (with mounted lens and USB 3.0 cable)
Weight	90 g
Dimensions	

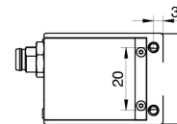
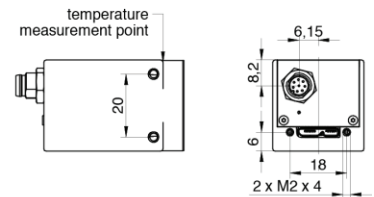
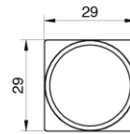
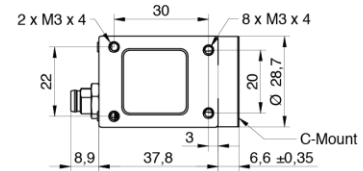

## Environmental Data

Storage Temperature	-10 °C ... + 70 °C
Operating Temperature	0 °C ... +65 °C @ T = Measurement Point or 0 °C ... +72 °C @ internal Temperature Sensor Note: Ambient temperature above 28 °C requires heat dissipation measures.
Int. Temperature Sensor	yes, accuracy: ±1 °C (typ) 0 °C ... +85 °C
Humidity	10 % ... 90 % non-condensing

<sup>1)</sup> the maximum temperature for Sony sensor characteristics (sensor performance) are guaranteed up to 50 °C @ Measurement Point or up to 58 °C @ internal temperature sensor

## LED Signalling

LED	Green flash	Power on, no link active
	Green	Link active USB 3.0
	Red	Error or Link active USB 2.0
	Yellow	Sensor Readout activity
	Red flash	Update

## Electrical Data

Power Supply	bus powered via USB3.0 interface
Power Consumption	approx. 3.5 W @ 31 fps (Factory Setting "Default")
Digital Input	Optocoupler $U_{IN(low)}$ : 0.0 ... 4.5 VDC $U_{IN(high)}$ : 11.0 ... 30.0 VDC $I_{IN}$ : 3.0 ... 10.0 mA min. Impulse Length: 2.0 $\mu$ sec
Digital Output	Optocoupler $U_{EXT}$ : 5 ... 30 V DC $I_{OUT}$ : max. 50 mA $t_{ON}$ = typ. 3 $\mu$ sec $t_{OFF}$ = typ. 40 $\mu$ sec
GPIO	direct, without optocoupler
GPIO used as Input:	$U_{IN(low)}$ : 0.0 ... 0.8 VDC $U_{IN(high)}$ : 2.0 ... 30.0 VDC min. Impulse Length: 2.0 $\mu$ sec
GPIO used as Output:	$U_{Out(low)}$ : 0.0 ... 0.4 VDC ( $I_{sink\ max}$ : 50 mA) $U_{Out(high)}$ : 2.4 ... 3.3VDC ( $I_{max}$ : 1 mA)
Caution 	* The General Purpose I/Os (GPIOs) are not potential-free and do not have an overrun cut-off. Incorrect wiring (overvoltage, undervoltage or voltage reversal) can lead to defects in the electronic system. Ground loops are to be avoided and can lead to destruction of the device.

## Conformity

Conformity	CE, RoHS, REACH
KC Registration No. / Date	- / -
MTBF	46 years @ T = 45 °C / 31 years @ T = 60 °C T = Measurement Point

## GeniCam™ Features

Short Exposure Range	yes, ShortExposureTimeEnable Short Exposure Range 1 $\mu$ sec ... 60 sec Default Exposure Range 15 $\mu$ sec ... 60 sec
Timer	Timer Selector: Timer Selector: Timer 1 TimerTriggerSource: Line0, SoftwareTrigger, ExposureStart, ExposureEnd, FrameTransferSkipped, TriggerSkipped, Off TimerDelay: 0 $\mu$ sec ... 2 sec, Step Size: 1 $\mu$ sec TimerDuration: 4 $\mu$ sec ... 2 sec, Step Size: 1 $\mu$ sec
Counter	Counter Selector: Counter 1, Counter 2 CounterValue: 0 ... 65535 Counter Event Source: Counter1End or Counter2End, ExposureActive, FrameTransferSkipped, FrameTrigger, TriggerSkipped, Line0..2 and Off Counter Reset Source: Counter1End, Counter2End, Line0..2
Sequencer	Sequencer Characteristics: up to 128 sets, up to 4 possible pathes for triggered set transitions, 6 trigger sources: Counter1End, Counter2End, ExposureActive, Line0..2, ReadoutActive, Timer1End Sequencer Parameters for Exposure, Gain, Trigger, ROI and Output: ExposureTime, CounterDuration, CounterEventActivation, CounterEventSource, CounterResetSource, ExposureMode, ExposureTime, Gain, Height, OffsetX, OffsetY, TriggerMode, UserOutputValue, UserOutputValueAll, Width

## GenICam™ Features

User Sets	Factory Settings: UserSet0 (read only) Freely Programmable: UserSet1, UserSet2, UserSet3 Parameters: any user definable Parameter
Acquisition Abort	Delay up to 34.5 msec
Chunk Data	yes, Chunk Selector: Binning, BlackLevel, CounterValue, DeviceTemperature, ExposureTime, FrameID, Gain, Height, Image, ImageControl, LineStatusAll, OffsetX, OffsetY, PixelFormat, SequencerSetActive, Timestamp, Width
Device Temperature	InHouse Event generation for Normal to High, High to Exceeded and Exceeded to Normal Exceeded (no image transfer) = max. internal temperature sensor + 1 °C
Device Link Throughput Limit	yes, up to max. Device Link Speed
Custom Data	yes, 128 Byte with CustomDataKonfiguration Mode
Calibration Data	yes, camera calibration values can stored: CalibrationMatrix, CalibrationMatrixNew, CalibrationFocalLenght, CalibrationAngularAperture, GeometryDistortionValue: k1, k2, p1, p2, k3, CalibrationVector: tvec, rvec and CalibrationDataVersion
SFNC Version	2.4.0

## Factory Settings after Start-Up

Trigger Mode	Off (Free Running)
Analog Controls	Exposure Time: 4 msec, Gain: 0 dB, Offset: 0
Pixel Format	BayerRG8
Partial Scan	Off
Acquisition Frame Rate	Off
Timer/Counter/Sequencer	Off
Defect Pixel Correction	ON
Fixed Pattern Noise Correction	-
Digital Input	Line0, invert = false
Digital Output	Line3, invert = false, line source = Off
GPIO 1/2	Line1, Line2, invert = false, LineMode = Input
TriggerSource	All

**Partial Scan** @ FullFrame, min Exposure, Mono8 (monochrome camera) or BayerRG8 (color camera)

	Resolution	max. fps acquisition	max. fps interface <sup>2)</sup>
UHD (4K)	3840 x 2160	43	43
Full HD	1920 x 1080	84	84
SXGA	1280 x 1024	88	88
HD720	1280 x 720	123	123
XGA	1024 x 768	116	116
SVGA	800 x 600	145	145
VGA	640 x 480	178	178
CIF	352 x 288	276	276
QVGA	320 x 240	321	321
QCIF	176 x 144	472	472
LineScan	4096 x 2048	45	45
	4096 x 1024	88	88
	4096 x 512	168	168
	4096 x 256	304	304
	4096 x 128	512	512
	4096 x 64	777	777
	4096 x 32	1049	1049
	4096 x 16	1271	1271
	4096 x 8	1421	1421
	4096 x 4	1511	1511
	4096 x 2	1560	1560
	4096 x 1	1560	1560

<sup>2)</sup> depends on the used interface

Distribution in the UK & Ireland



**Lambda Photometrics Limited**

Lambda House Batford Mill

Harpenden Herts AL5 5BZ

United Kingdom

**Characterisation,  
Measurement &  
Analysis**

**E: [info@lambdaphoto.co.uk](mailto:info@lambdaphoto.co.uk)**

**W: [www.lambdaphoto.co.uk](http://www.lambdaphoto.co.uk)**

**T: +44 (0)1582 764334**

**F: +44 (0)1582 712084**