

¹⁾ Sensor readout, different from pixel format

²⁾ depends on the used interface



Sensor Information

Model Name	Sony IMX287
Type	1/2.9" progressive scan CMOS
Shutter	Global Shutter
Resolution	720 x 540 pixels
Scan Area	7.07 mm x 5.30 mm
Pixel Size	6.9 μm x 6.9 μm

Data Quality

@ 20 °C, gain = 1, exposure time = 4 msec

Dark Noise (σ)	3 e- typical
Saturation	9500 e- typical
Dynamic Range	70 dB typical
SNR	40 dB typical
Quantum efficiency η	47 % @ 465 nm, 58 % @ 536 nm, 53 % @ 631 nm typical

Acquisition

Resolution	720 px x 540 px		
Interface Frame Rate (depends on used interface performance)	Format	Resolution	max. Frame Rate (@ Trigger Mode) ²⁾
	Full Frame	720 x 540	430 fps
	Binning 2x2	360 x 270	430 fps
	Binning 2x1	360 x 540	430 fps
	Binning 1x2	720 x 270	430 fps
Acquisition Frame Rate ¹⁾	434 fps $t_{\text{readout}} = 2.31 \text{ msec}$ (max. Res. Full Frame) @ 10 bit		
	318 fps $t_{\text{readout}} = 3.15 \text{ msec}$ (max. Res. Full Frame) @ 12 bit		
Pixel Formats	BayerRG8, BayerRG10, BayerRG12, BayerRG12p Mono8, Mono10, Mono12p, RGB8, BGR8		
Partial Scan	True Partial Scan with increasing Frame Rate on Y direction, Region of Interest (ROI) arbitrary Width: minimum 16, increment 16 Height: minimum 4, increment 4		
Adjustable Acquisition Frame Rate	Off or 0.01 ... 4694 Hz		
Acquisition Mode	Continuous, Single Frame and Multi Frame		
Acquisition Status	AcquisitionActive, AcquisitionTrigger Wait		
Exposure Mode	Timed		
Shutter Mode	-		
Readout Mode	Overlapped, Sequential		

Image Pre-Processing

Analog Controls	Exposure Time (1 μsec ... 60 sec Step Size 1 μsec) Gain (0...48 dB), Offset (0 ... 255 LSB 12 bit)
Gamma Correction	Gamma (0.1 ... 2 available if LUT is enabled)
LUT	Luminance (12 bit)
Color Models	Mono, Raw Bayer, RGB and BGR
Color Processing	Integrated color processor for high quality color calculation
Color Adjustment	Manual White Balance Automatic White Balance (Once or Continuous)
Color Enhancement	Color Transformation to sRGB color space by optimized Matrix for 6500 K, 3000 K Lightsource or User defined Matrix
Color Tolerance	-
Binning Horizontal	1 or 2
Binning Vertical	1 or 2
Image Flipping	Horizontal, vertical
Defect Pixel Correction	via Defect Pixel List with up to 512 Pixel Coordinates
Fix Pattern Noise	-
Correction	

Digital Output: Low Active

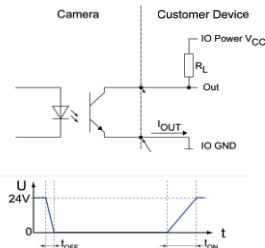

Digital Input

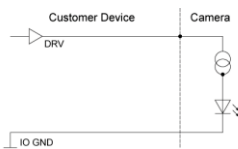

Trigger Mode: Start up time and valid Trigger

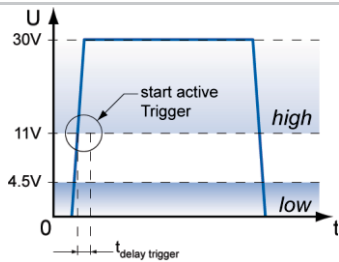

GPIO

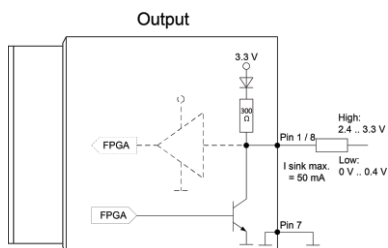
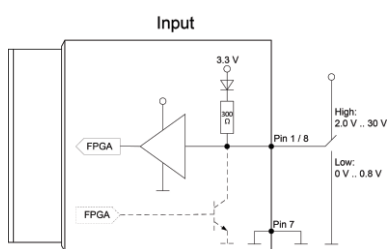

Process Synchronization

Trigger Mode	Off (Free Running), On (Trigger)
Trigger Overlap Type	Readout
Trigger Sources	Hardware (Line0,1,2), Software, All or Off fixed Trigger Delay out of t _{readout} : ¹⁾ 44.8 μsec @ 10 bit 49 μsec @ 12 bit max. Trigger Delay during t _{readout} : ¹⁾ 43.7 μsec @ 10 bit 49.4 μsec @ 12 bit
Trigger Delay	0 ... 2 sec, Tracking and buffering of up to 256 triggers
External Flash Sync	via Exposure Active t _{delay flash} ≤ 3 μsec, t _{duration} = t _{exposure}

Digital I/Os

Lines	Input: Line 0, Output: Line3, GPIO: Line 1, Line 2
Output Sources	Off, ExposureActive, Timer1, ReadoutActive, UserOutput 1-3 and TriggerReady
Line Debouncer	Low and high signal separately selectable Debouncing Time 0 ... 5 msec, Step Size: 1 μsec

Memory

Image Buffer	356 MB 320 Images (Trigger Mode) / 1 Image (Free Running Mode)
Non-volatile Memory	128 kb

Interface Data

Interface	USB3.0 (5000 Mbits/sec)
USB Vendor ID / Product ID	0x2825 / 0x15A

USB 3 Vision® Features

Events Transmission via Asynchronous Message Channel	DeviceTemperatureStatusChanged, EventLost, ExposureEnd, ExposureStart, FrameEnd, FrameStart, FrameTransferSkipped, Line0..3 FallingEdge, Line0..3 RisingEdge, TransferBufferFull, TransferBufferReady, TriggerOverlapped, TriggerReady, TriggerSkipped up to 2 ³²
Frame Counter	up to 2 ³²
Payload Size	0 ... 1166600 Byte
Timestamp	64 bit, resolution in nsec, increment = 8
USB Vision	v1.0.1

¹⁾ Sensor readout, different from pixel format

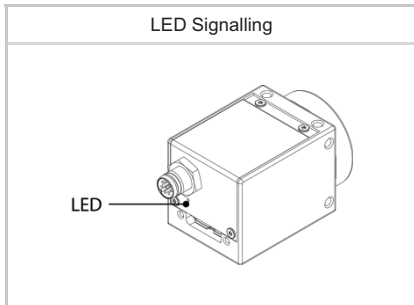
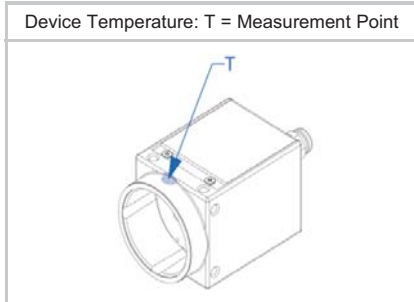
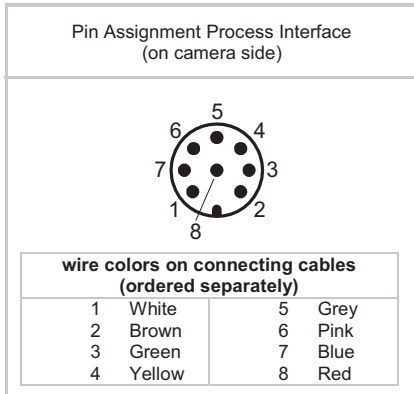
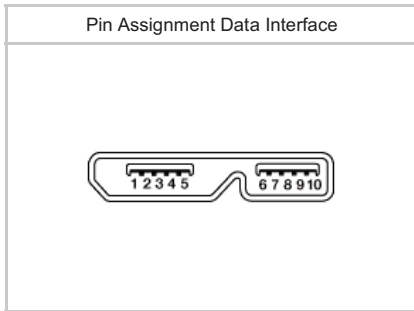

Interfaces and Connectors

Data and Power Interface	USB 3.0	Transfer Rate	5000 Mbits/sec
	USB 2.0	Transfer Rate	480 Mbits/sec
	Connector:		USB 3.0 Micro B
Process Interface	Pin Assignment:	1 - VBUS	6 - MicB_SSTX-
		2 - D-	7 - MicB_SSTX+
		3 - D+	8 - GND_DRAIN
		4 - ID	MicB_SSRX-
		5 - GND	MicB_SSRX+
	Connector:	M8/8-pin (SACC-DSI-M8MS-8CON-M8-L180)	
	Assignment:	1 - GPIO (Line2)	5 - Power VCC
		2 - not connected	OUT1
	3 - IN1 (Line0)	6 - OUT1 (Line3)	
	4 - GND IN1	7 - GND GPIO	
		8 - GPIO (Line1)	

Caution



* Note GPIOs: Ground loops are to be avoided and can lead to destruction of the device.

Optical Data

Lens Mount	C-Mount
Optical Filter	IR cut filter

Mechanical Data

Housing	Zinc die casting, nickel-chrome-plated, IP40 (with mounted lens and USB 3.0 cable)
---------	--

Dimensions

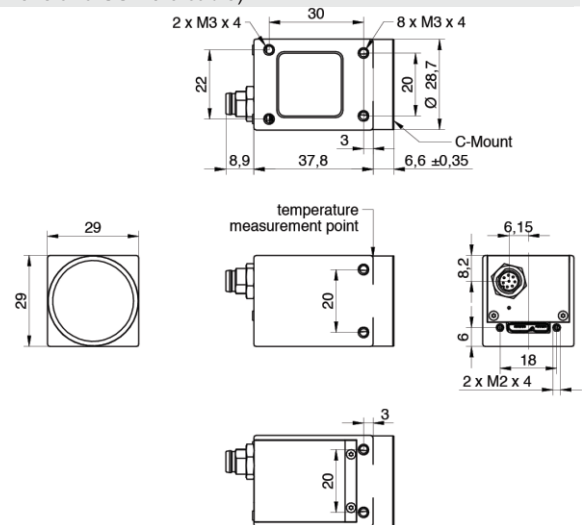

Weight	90 g
--------	------

Environmental Data

Storage Temperature	-10 °C ... + 70 °C
Operating Temperature ¹⁾	+5 °C ... +65 °C @ T = Measurement Point or +5 °C ... +72 °C @ internal Temperature Sensor Ambient temperature above 35 °C requires heat dissipation measures.
Int. Temperature Sensor	yes, accuracy: ±1 °C (typ) 0 °C ... +85 °C
Humidity	10 % ... 90 % non-condensing

¹⁾ the maximum temperature for Sony sensor characteristics (sensor performance) are guaranteed up to 50°C @ Measurement Point or 56°C @ internal temperature sensor

LED Signalling

LED	Green flash	Power on, no link active
	Green	Link active USB 3.0
	Red	Error or Link active USB 2.0
	Yellow	Sensor Readout activity
	Red flash	Update

Electrical Data

Power Supply	bus powered via USB3.0 interface
Power Consumption	approx. 2.6 W @ 430 fps (Factory Setting "Default")
Digital Input	Optocoupler $U_{IN(low)}$: 0.0 ... 4.5 VDC $U_{IN(high)}$: 11.0 ... 30.0 VDC I_{IN} : 3.0 ... 10.0 mA min. Impulse Length: 2.0 μ sec
Digital Output	Optocoupler U_{EXT} : 5 ... 30 V DC I_{OUT} : max. 50 mA t_{ON} = typ. 3 μ sec t_{OFF} = typ. 40 μ sec
GPIO	direct, without optocoupler
GPIO used as Input:	$U_{IN(low)}$: 0.0 ... 0.8 VDC $U_{IN(high)}$: 2.0 ... 30.0 VDC min. Impulse Length: 2.0 μ sec
GPIO used as Output:	$U_{Out(low)}$: 0.0 ... 0.4 VDC ($I_{sink\ max}$: 50 mA) $U_{Out(high)}$: 2.4 ... 3.3VDC (I_{max} : 1 mA)
Caution 	* The General Purpose I/Os (GPIOs) are not potential-free and do not have an overrun cut-off. Incorrect wiring (overvoltage, undervoltage or voltage reversal) can lead to defects in the electronic system. Ground loops are to be avoided and can lead to destruction of the device.

Conformity

Conformity	CE, RoHS, REACh
KC Registration No. / Date	- / -
MTBF	60 years @ T = 45 °C / 39 years @ T = 60 °C T = Measurement Point

GeniCam™ Features

Short Exposure Range	yes, ShortExposureTimeEnable Short Exposure Range 1 μ sec ... 60 sec Default Exposure Range 15 μ sec ... 60 sec
Timer	Timer Selector: Timer Selector: Timer 1 TimerTriggerSource: Line0, SoftwareTrigger, ExposureStart, ExposureEnd, FrameTransferSkipped, TriggerSkipped, Off TimerDelay: 0 μ sec ... 2 sec, Step Size: 1 μ sec TimerDuration: 4 μ sec ... 2 sec, Step Size: 1 μ sec
Counter	Counter Selector: Counter 1, Counter 2 CounterValue: 0 ... 65535 Counter Event Source: Counter1End or Counter2End, ExposureActive, FrameTransferSkipped, FrameTrigger, TriggerSkipped and Off Counter Reset Source: Counter1End, Counter2End, Line0 and Off
Sequencer	Sequencer Characteristics: up to 128 sets, up to 4 possible pathes for triggered set transitions, 6 trigger sources: Counter1End, Counter2End, ExposureActive, Line0, ReadoutActive, Timer1End Sequencer Parameters for Exposure, Gain, Trigger, ROI and Output: ExposureTime, CounterDuration, CounterEventActivation, CounterEventSource, CounterResetSource, ExposureMode, ExposureTime, Gain, Height, OffsetX, OffsetY, TriggerMode, UserOutputValue, UserOutputValueAll, Width

Distribution in the UK & Ireland



**Characterisation,
Measurement &
Analysis**

Lambda Photometrics Limited
Lambda House Batford Mill
Harpenden Herts AL5 5BZ
United Kingdom
E: info@lambdaphoto.co.uk
W: www.lambdaphoto.co.uk
T: +44 (0)1582 764334
F: +44 (0)1582 712084

GenICam™ Features

User Sets	Factory Settings: UserSet0 (read only) Freely Programmable: UserSet1, UserSet2, UserSet3 Parameters: any user definable Parameter
Acquisition Abort	Delay up to 3.2 msec
Chunk Data	yes, Chunk Selector: Binning, Black Level, DeviceTemperature, ExposureTime, FrameID, Gain, Height, Image, ImageControl, LineStatusAll
Device Temperature	InHouse Event generation for Normal to High, High to Exceeded and Exceeded to Normal Exceeded (no image transfer) = max. internal temperature sensor + 1 °C
Device Link Throughput Limit	yes, up to max. Device Link Speed
SFNC Version	v2.3

Factory Settings after Start-Up

Trigger Mode	Off (Free Running)
Analog Controls	Exposure Time: 4 msec, Gain: 0 dB, Offset: 0
Pixel Format	BayerRG8
Partial Scan	Off
Acquisition Frame Rate	Off
Timer/Counter/Sequencer	Off
Defect Pixel Correction	ON
Fixed Pattern Noise Correction	-
Digital Input	Line0, invert = false
Digital Output	Line3, invert = false, line source = Off
GPIO 1/2	Line1, Line2, invert = false, LineMode = Input
TriggerSource	All

Partial Scan @ FullFrame, min Exposure, Mono8 or BayerRG8

	Resolution	max. fps acquisition	max. fps interface ²⁾
VGA	640 x 480	480	480
CIF	352 x 288	750	750
QCIF	176 x 144	1301	1301
LineScan	720 x 512	453	453
	720 x 256	828	828
	720 x 128	1415	1411
	720 x 64	2194	2171
	720 x 32	3023	2892
	720 x 16	3734	3691
	720 x 8	4223	4205
	720 x 4	4529	4527
	720 x 2	4529	4516
	720 x 1	-	-

²⁾ depends on the used interface