

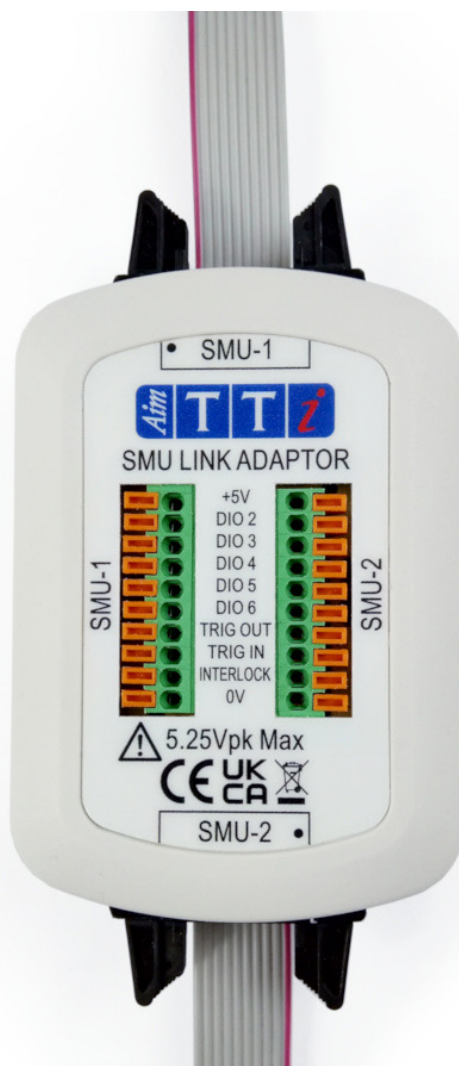

INSTRUCTION MANUAL

EN



LINK ADAPTOR

For SMU4000 Series

Distribution in the UK & Ireland



Characterisation,
Measurement &
Analysis

Lambda Photometrics Limited
Lambda House Batford Mill
Harpenden Herts AL5 5BZ
United Kingdom
E: info@lambdaphoto.co.uk
W: www.lambdaphoto.co.uk
T: +44 (0)1582 764334
F: +44 (0)1582 712084

CONTENTS

INTRODUCTION	2
CONNECTING THE LINK ADAPTOR TO THE SMUS	3
SYNCHRONISING 2 SMUS	4
DIO EXPANDER	6
TEST BRIDGE SMU	9

Symbols

The following symbols are displayed on the instrument and throughout the manual, to ensure the safety of the user and the instrument, all information must be read before proceeding.

CAUTION



Indicates a hazard that could damage the product that may result in loss of important data or invalidation of the warranty.

NOTE



Indicates a helpful tip.

TIPS



Indicates an advisory tip or FAQ (Frequently asked question).

	UKCA 'UK Conformity Assessed' marking is a certification mark that affirms conformity with the applicable requirements for products sold within Great Britain.
	'CE' marking is a certification mark that affirms the good's conformity with European health, safety, and environmental protection standards.
	WEEE (do not dispose in household waste)



User manuals, additional support and service information can be found at:
www.aimtti.com/support

1. INTRODUCTION

For use with the SMU4000 Product Series:

SMU4001 & SMU4201

This SMU Link Adaptor is designed to connect two Aim-TTi SMUs together via the DIO terminal ports on the rear panel.

It can also be used as a DIO Expander for one or two instruments, removing the need to wire each DIO terminal individually.

Push terminal access is provided to all DIO port pins, the minimum recommended cable diameter is 0.4mm, the maximum is 0.8mm.

CAUTION



5.25Vpk Max input voltage.

Always use shrouded ferrules to prevent the risk of shock.



In this Kit:

1 x SMU Link Adaptor

2 x 280mm 10 way ribbon cable

1 x Instruction leaflet

2. CONNECTING THE LINK ADAPTOR TO THE SMUS

The Link Adaptor mates with standard 10W (2 x 5 DIL) female 2.54mm pitch IDC ribbon cable.

Connecting to the SMU

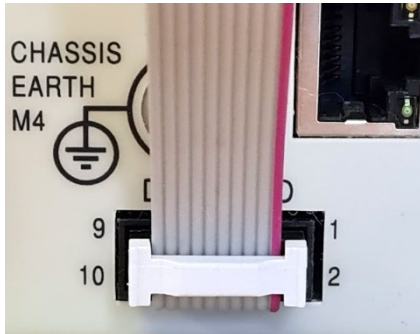

Image for illustration purposes only.

Strain relief has been added to the SMU connection end of the ribbon cable to allow the cable to be removed without damaging the cable.

The cable must be fitted with the red stripe towards pin 1.



Connecting to the Link Adaptor

Ensure the cable is fitted with the red stripe towards the black dot on the Link Adaptor

To fit the cable to the link adaptor:

1. Open the connector holder as shown.
2. Push the cable into the adaptor, the connector holder will close as the cable is pushed in.
3. Push until the connector holder is fully closed.

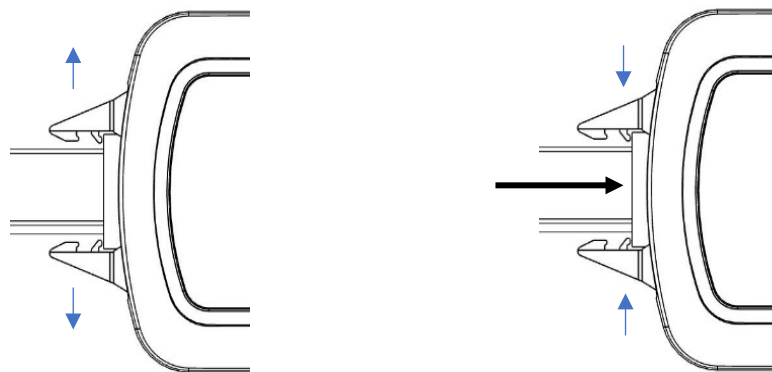

3. SYNCHRONISING 2 SMUS

A fully functioning two channel SMU can be created with two SMUs via a handshake triggering system using the Link Adaptor to connect the trigger DIO lines.

NOTE



When using the Link adaptor to connect two SMUs, the adaptor *internally* connects the 'Trigger In' of each SMU to the 'Trigger Out' of the other. 'Trigger Out' will be set once all measurements associated with the level / shape are complete.

This combination of 'Trigger in' and 'Trigger Out' allows for the handshaking of multiple instruments without further wiring.

For full synchronisation of two SMUs, consider the following settings with the 'Manual Setup' of the SMU:

To initialise the test, both SMUs must be 'RUN'.

The DIO must all be set to either active high or active low on both instruments.
CNFG > [System] Interfaces > [DIO] Pin Action

A trigger (either level or shape) must be set on both instruments, A shape other than steady must be selected to set the trigger.
CNFG > [Source Measure Action] Manual Setup > [Timing] Trigger

4. DIO EXPANDER

As well as connecting 2 SMUs together, the SMU Link Adaptor can be used with a single SMU as a DIO expander- removing the need to wire each DIO terminal individually.

SMU-1 / SMU-2

The DIO terminal connections detailed in this section can be used for up to two SMUs via the SMU-1 and SMU-2 connections.

SMU-1 terminals **(a)** are extended from the connection labelled SMU-1 **(b)**.

SMU-2 terminals **(c)** are extended from the connection labelled SMU-2 **(d)**.

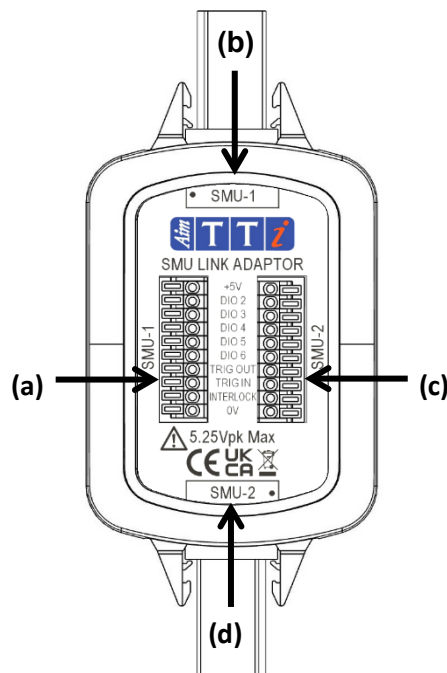

Connecting to the DIO terminals

The Link Adaptor provides push terminal access to all DIO port pins, the minimum recommended cable diameter is 0.4mm, the maximum is 0.8mm.

Always use shrouded ferrules to prevent the risk of shock.

Press the orange actuators of the push terminals, insert the connecting wire and release the actuator to secure the connection.

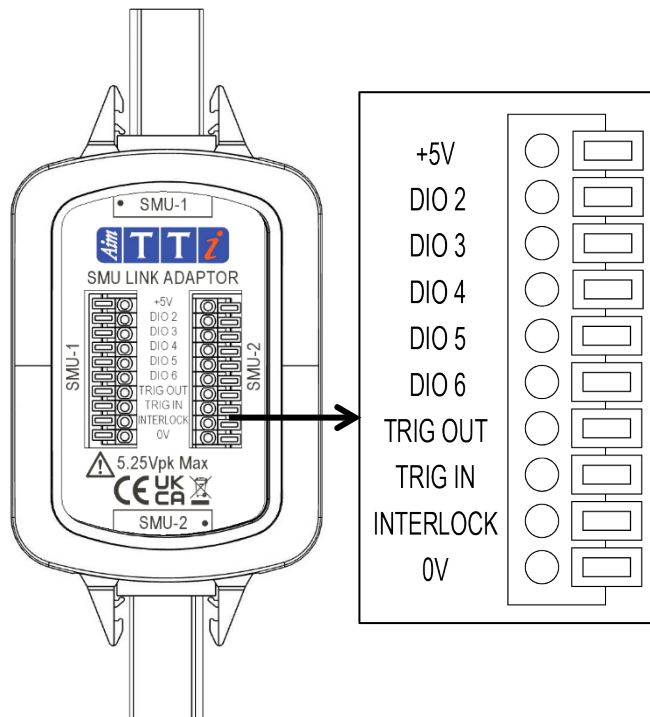

+5V / 0V

These lines are provided for powering external control circuitry. The 5V supply is internally fused (resettable fuse) to 500mA.

DIO 2-6 (General)

DIO configuration is exclusively for use with sequence mode. Used for triggering input and output events from within a sequence, allowing a defined sequence to control or be controlled by external circuitry.

TRIG(ger) IN / OUT

Triggered control of the timing of shape waveforms. Used to step through the points of a shape waveform, or to repeat shape waveforms. Once the event has been triggered and all associated measurements to that event have been made, the instrument sets a global trigger output on the DIO port.

The adaptor connects the 'TRIG(ger) IN' of each SMU to the 'TRIG(ger) OUT' of the other.

INTERLOCK (High Voltage)

Controls the High Voltage (HV) interlock via external circuitry. When controlled via the DIO, the High Voltage Interlock works independently from the password protection; when activated or deactivated, the password protection is not required to be removed.

Input / Output

Each DIO line can be configured as an Input or an Output from the SMU.

CNFG > [System] Interfaces > [DIO] Configure

CAUTION



5.25Vpk Max input voltage.

Always use shrouded ferrules to prevent the risk of shock.

Input levels:

Input allows an external device to control the state of the line.

When using as a input, the resting state is always high (4.7kohm pull-up (internal) to +5V).

Logic Zero (low): -0.25V to +1V (diode clamped to 0V).

Logic One (high): +1.75V to +5.25V (diode clamped to +5V).

Output Levels:

Output allows the SMU to control the state of the line on external device.

When using as an output, the active high resting state will be low and the active low resting state will be high.

Logic zero (low): open-drain MOS, typically 0.2ohm, 100mA maximum sink.

Logic one (high): nominally 4.7kohm pull-up (internal) to +5V.

5. TEST BRIDGE SMU

Test Bridge SMU simplifies the test setup when using multiple instruments allowing the complete control of one or two instruments from one place.



This program also provides advanced graphing features which enable results from multiple SMUs to be plotted on a single graph, including options to split the data into steps and repeats for further analysis.

Test Bridge SMU is a free software program, available to download from www.aimtti.com/support

EXCELLENCE THROUGH EXPERIENCE

Aim-TTi is the trading name of Thurlby Thandar Instruments Ltd. (TTi), one of Europe's leading manufacturers of test and measurement instruments.

The company has wide experience in the design and manufacture of advanced test instruments and power supplies built up over more than thirty years.

The company is based in the United Kingdom, and all products are built at the main facility in Huntingdon, close to the famous university city of Cambridge.

TRACEABLE QUALITY SYSTEMS

TTi is an ISO9001 registered company operating fully traceable quality systems for all processes from design through to final calibration.



ISO9001:2015

Certificate number FM 20695

WHERE TO BUY AIM-TTI PRODUCTS

Aim-TTi products are widely available from a network of distributors and agents in more than sixty countries across the world.

To find your local distributor, please visit our website which provides full contact details.



Distribution in the UK & Ireland



Lambda Photometrics Limited

Lambda House Batford Mill

Harpenden Herts AL5 5BZ

United Kingdom

E: info@lambdaphoto.co.uk

W: www.lambdaphoto.co.uk

T: +44 (0)1582 764334

F: +44 (0)1582 712084

Designed and built in Europe by:



48591-1500 Issue 1